

Instruction

# Disassembling and assembling APP S 674 3.0-3.5 pumps

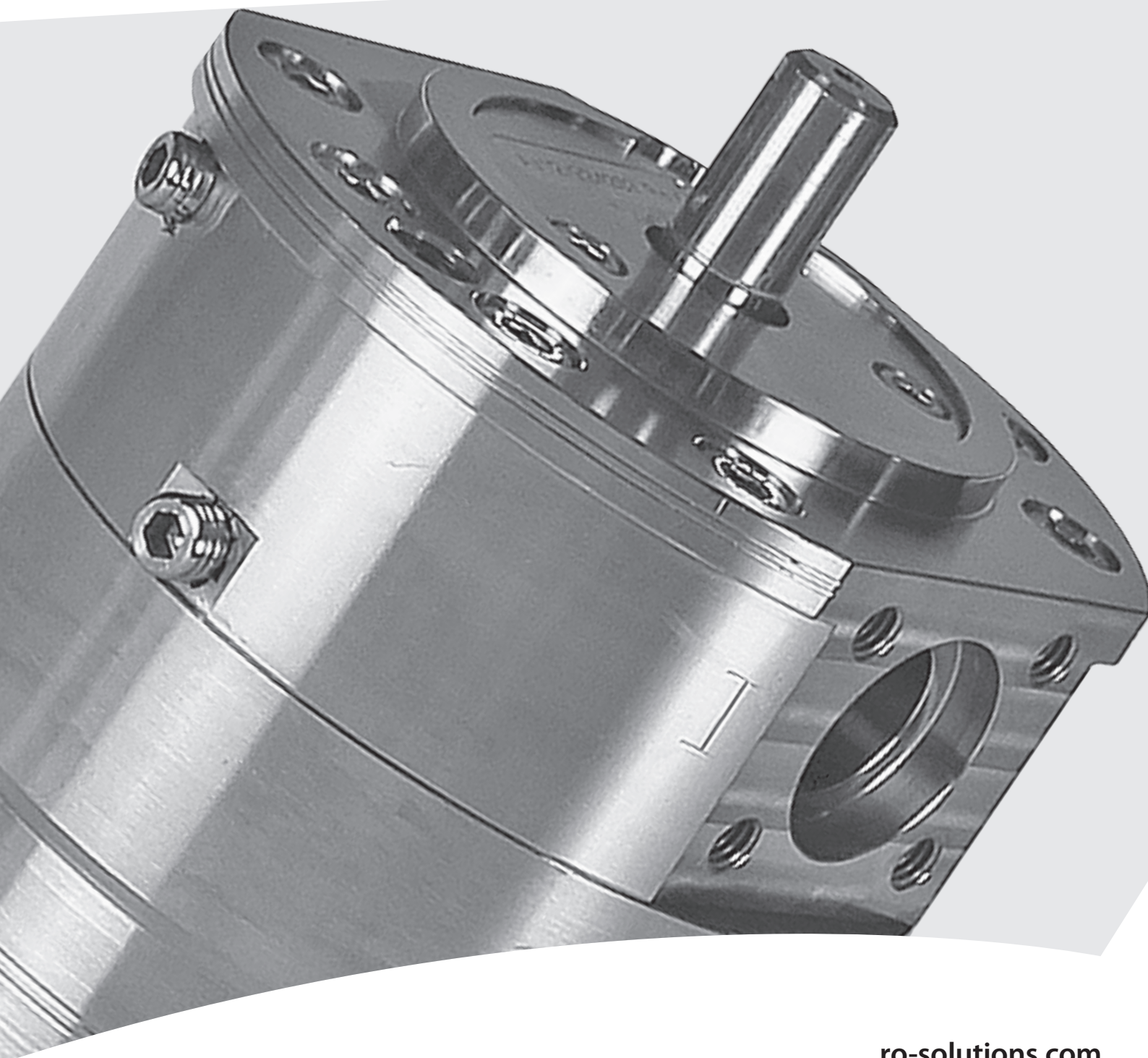

---

**Instruction** **Disassembling and assembling APP S 674 3.0-3.5**

---

<b>Table of Contents</b>	1.	Introduction .....	3
	2.	Disassembling the pump .....	3
	3.	Assembling the pump .....	8
	4.	Disassembling and assembling of the swash plate .....	14
	5.	Disassembling and assembling of cylinder barrel and valve plate .....	15
	6.	Disassembling and assembling of the flushing valve .....	16
	7.	How to replace the shaft seal .....	17
	8.	Changing pistons .....	17
	8.1	Disassembling .....	17
	8.2	Assembling .....	19
9.	Exploded view APP S 674 3.0-3.5 pumps .....	21	
10.	When should the pistons be replaced .....	22	

---

**This document covers the instructions for  
disassembling and assembling the axial piston  
pumps APP S 674 3.0-3.5.**

**Instruction**
**Disassembling and assembling APP S 674 3.0-3.5**
**1. Introduction**

**Important:** It is essential that the pump is serviced in conditions of absolute cleanliness.

For a better understanding of the pump, please see the exploded view in item 9.

**Note:**

**When disassembling and assembling it must be possible to place the pump vertically with the shaft pointing downwards. This can be done with a distance block with a minimum height of 50 mm.**

**Tools needed:**

- 6 mm allen key
- 8 mm allen key
- Torque wrench
- 2 screwdrivers
- 1 press bush tool (part of seal kit)
- Distance block

**2. Disassembling the pump**

1. Disconnect the pump from the rest of the system.



2. Using a 6 mm allen key, unscrew the 3 bolts from shaft seal cover.



3. Remove shaft seal bushing.



4. Remove O-ring with a small screwdriver.



5. Remove ceramic ring from cover by carefully pushing it from the back of the sealing ring with a screwdriver.



6. Clean and then wet the shaft with clean water.



7. Through the inlet port lever the shaft seal with a screw driver between shaft seal and spring. Use one hand to pull the shaft seal up.

**WARNING:**  
Be careful not to scratch the shaft.

8. Carefully remove the shaft seal and distance ring.



9. Carefully remove the spring by lifting it with a screwdriver and one hand to pull the spring up.



10. Using a 8 mm allen key, unscrew all bolts on the end flange.



11. Place pump on a distance block. Make sure there is enough free space for the shaft beneath the housing. Remove all bolts.

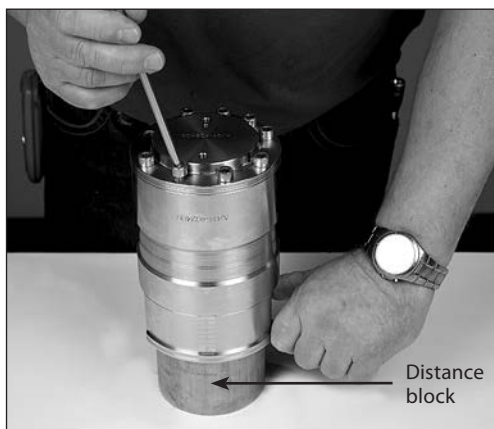

12. Remove end flange.



13. Swash plate must be placed so that its surface is not scratched. For further disassembling of swash plate, see page 14.



14. Remove the 2 pistons. Be careful not to scratch the pistons.

**WARNING:**  
Do not use any tools.



15. Remove the retainer plate with the remaining pistons.



16. Remove the retainer ball.



17. Remove the retainer guide and the spring.



18. Remove the guide pin.



19. Pull the cylinder barrel straight upwards in a continuous lift to ensure no damage of house bearing. This can only be done if the shaft seal is removed.

**WARNING:**  
If the cylinder barrel is dropped or lowered too fast into housing, the main bearing/shaft bearing might be damaged.



20. Place cylinder barrel upside down. For further disassembling of cylinder barrel and valve plate see page 15.



21. Remove the port plate in the housing by hand.

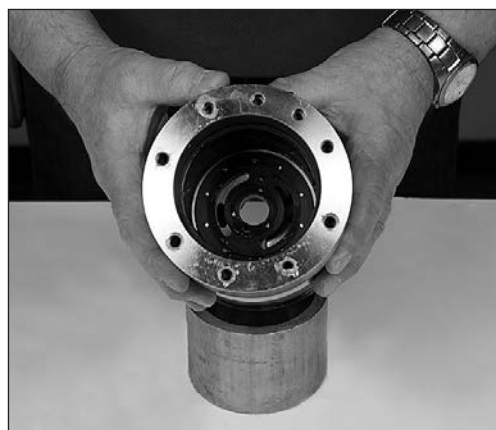

22. Remove the guide pin.

**Note:** The following operation is only necessary if O-ring on port flange has to be changed.

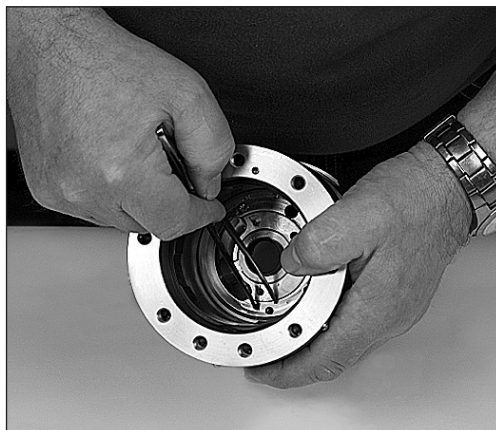

23. Turn the pump upside down. Unscrew the 8 bolts in port flange.



24. Remove bolts and port flange.



3. Assembling the pump

**WARNING:**  
Do not use silicone when assembling the pump. Do not reuse disassembled O-rings; they might be damaged. Always use new O-rings.

**Important:**  
It is essential that the pump is serviced in conditions of absolute cleanliness. All parts must be absolute clean before mounting.

1. Lubrication:
  - To prevent seizing-up, lubricate all threads with PTFE lubrication type.
  - O-rings inside pump may be lubricated only with clean filtered water.
  - O-rings for port flange, mounting flange and flushing valve must be lubricated.
  - It is important to lubricate ALL parts to be assembled with clean filtered water (Especially all PEEK parts).

2. Place the housing with pump label pointing downwards and insert guide pin for positioning the port flange on housing.



3. Mount new O-ring on port flange and lubricate with water.

4. Position port flange by aligning pin hole over guide pin.





5. Carefully press the port flange downwards. Do not squeeze the O-ring. If the O-ring is damaged, the pump will leak.



6. Lubricate the threads with PTFE lubrication. Insert screws on the port flange. Tighten screws to a torque of  $30 \pm 3$  Nm.



7. Place a 10.5 mm guide pin in the port flange.

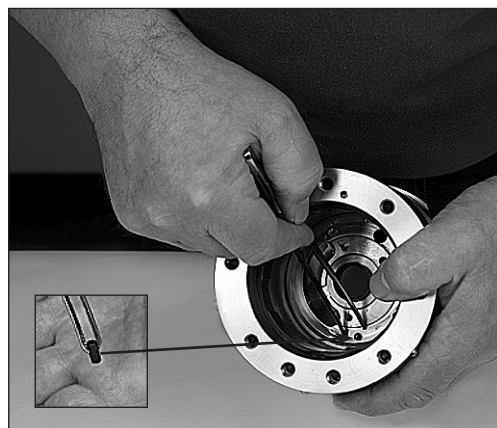

8. Position port plate by using the guide pin. Do not use force for this operation.



9. Ensure port plate is fitted tightly against the bottom.

**Important:** If valve plate is disassembled from cylinder barrel, please see page 15 before continuing.



10. Place the pump on a distance block. Make sure, there is enough free space for the shaft beneath the housing. Lubricate inside.

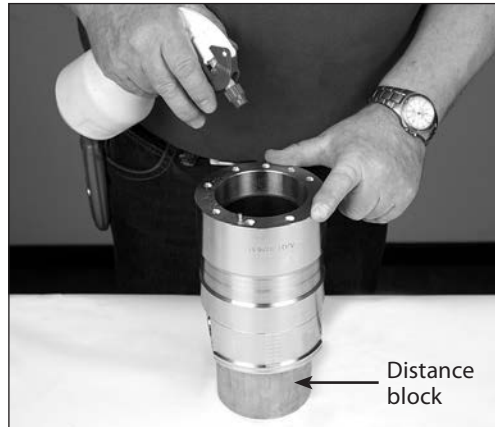

11. Carefully lower cylinder barrel into the housing.

**WARNING:**

If cylinder barrel is dropped or lowered too fast into housing, main bearing and shaft bearing might be damaged. Replacement can only be done at Danfoss, Nordborg.



12. Place the spring in cylinder barrel.



13. Lubricate and position the retainer guide.



14. Lubricate retainer guide and position the retainer ball.



15. Position the retainer plate.



16. Ensure the retainer plate is oriented correctly.

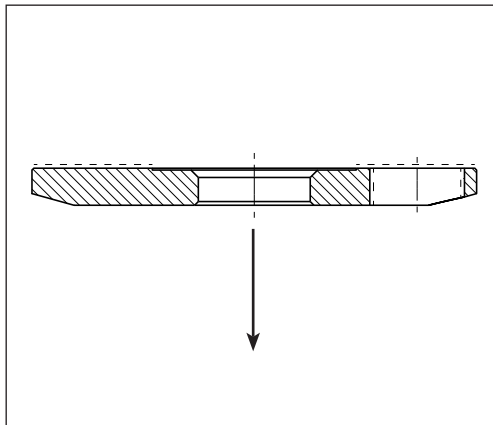

17. Lubricate and position the pistons in the retainer plate and cylinder barrel.



18. Lubricate the piston shoes. Tilt retainer plate for easier placement of swash plate. If the swash plate has been disassembled from end flange, see page 14 for assembling of swash plate. Remember to place the guide pin in the housing.



19. Change and lubricate O-ring in the end flange. Position end flange aligning pin hole over the guide pin.



20. Lubricate and place two bolts in end flange. Turn each bolt one round at a time to ensure mounting flange is mounted as straight downwards as possible. Be careful not to squeeze the O-ring.



21. Screw in the rest of the bolts and tighten all screws to a torque of 30 +/- 3 Nm.



22. Lubricate and press new ceramic ring into the shaft seal cover by using the press bush tool.

**WARNING:**  
Ensure that the face with rubber seal is positioned against shoulder in shaft seal flange.



23. Remove old O-ring and place the new one on shaft seal cover.



24. Position the shaft seal distance ring.



25. Lubricate shaft with clean filtered water.

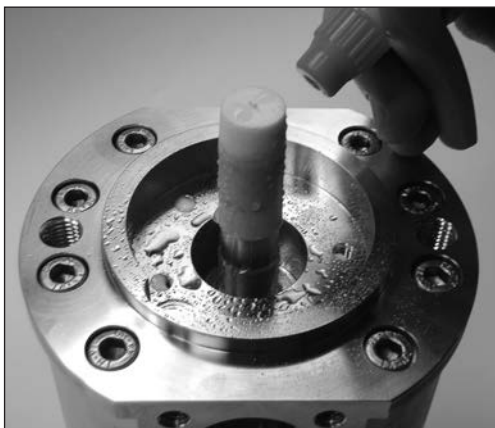

26. Mount new shaft seal with the carbon seal face pointing upwards. Press seal down and at the same time turn the seal clockwise until spring stops at distance ring.

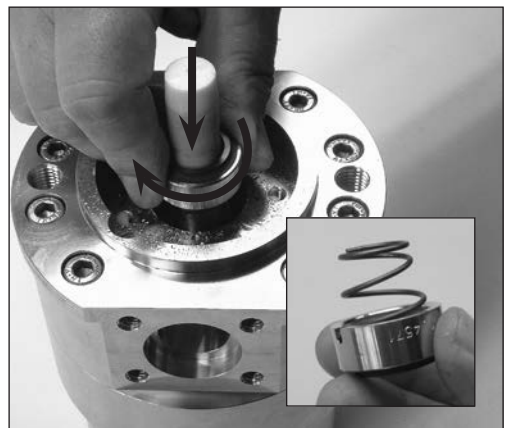

27. Right position of the spring can be inspected through the flushing valve hole. Shaft seal mounted.



28. Position the shaft seal cover on shaft. Be careful not to damage the ceramic ring.

**WARNING!**

Be careful, the shaft has sharp edges.



29. Hold the cover down with one hand and tighten the bolts with a torque of 12 Nm  $\pm$ 1 Nm.



**4. Disassembling and assembling of the swash plate**

1. Unscrew centre bolt from swash plate.



2. Remove swash plate, guide pin and O-ring.



3. Place guide pin and carefully align swash plate over guide pins.



4. Lubricate centre bolt thread with a PTFE lubricant type.



5. Position the centre bolt and tighten to 12 Nm  $\pm$  1 Nm.



6. Finally check the surface on the swash plate for any marks or foreign particles and place new O-ring.



**5. Disassembling and assembling of cylinder barrel and valve plate**

1. Carefully lift valve plate assembly free with the aid of a screwdriver.

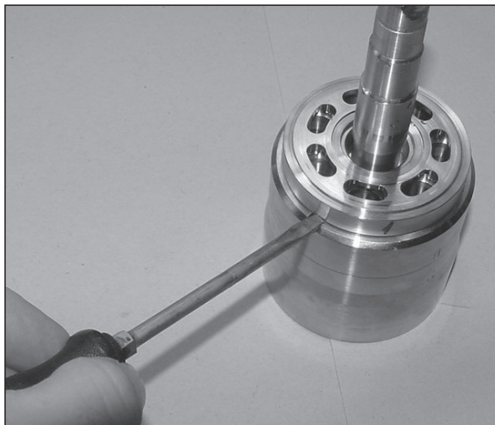

2. Replace O-rings and back-up rings on valve plate.



3. Mount the new back-up rings on the valve plate. Then mount the O-rings.

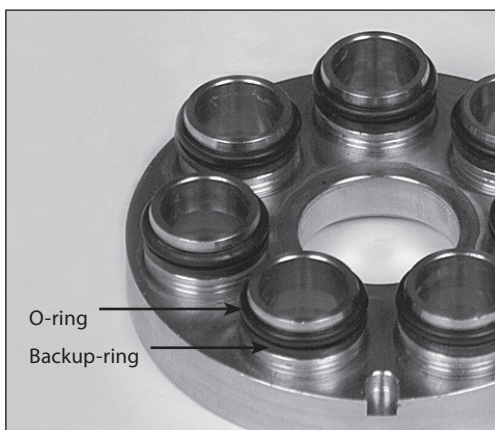

4. Lubricate the new O-rings/back-up rings and the liners in the cylinder barrel with clean filtered water.



5. Carefully press, by hand, valve plate onto cylinder barrel. The cylinder barrel is now ready for mounting.

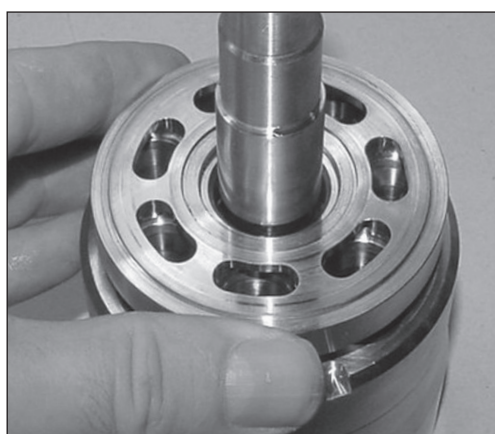

**6. Disassembling and assembling of the flushing valve**

1. Remove shaft seal cover.



2. Carefully push the flushing valve up through the outlet connection, using a small screwdriver.



3. Remove complete flushing valve set.



4. Flushing valve parts

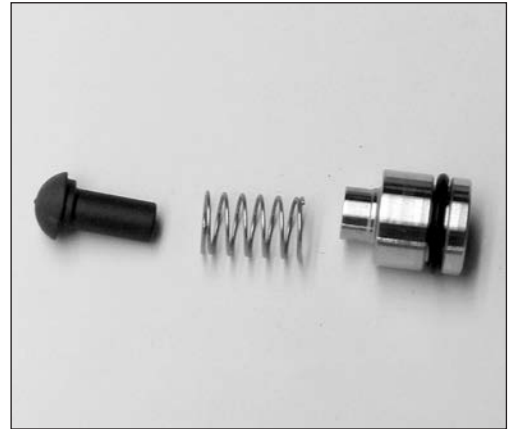

5. Press a new spring onto shoulders of the poppet guide and the poppet. The spring must be fastened on both collars. Then mount new O-ring on the poppet guide. Turn flushing valve upside down. If spring is not properly assembled, it will fall of.

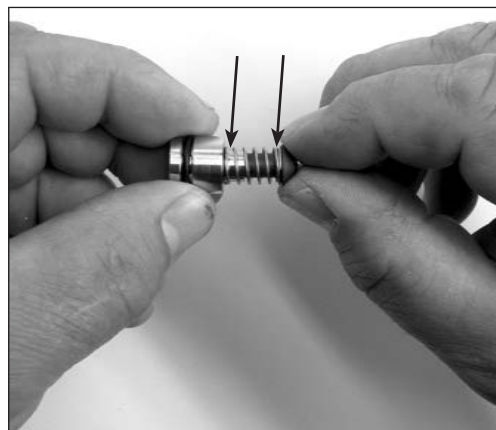

6. Lubricate valve with clean filtered water and push by hand the valve into the hole.





**Instruction**
**Disassembling and assembling APP S 674 3.0-3.5**
**7. How to replace the shaft seal**

Disassembling, please see	Assembling, please see
Page 3 items 2 to 4	Page 12 item 22 to 26
Page 4 items 5 to 6	Page 13 items 27 to 29

**8. Changing pistons**
**8.1 Disassembling**

To understand the pump design better, please see the exploded view in item 9.

1. Disconnect the pump from the rest of the system or close inlet valve.

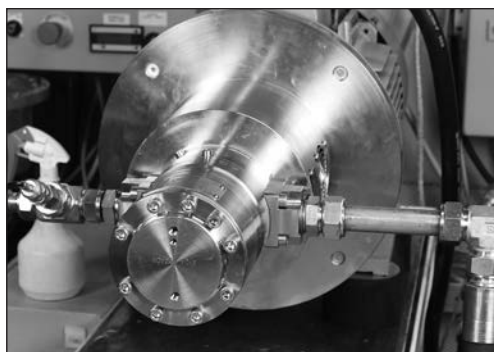

2. Loosen all screws on the pump except the two screws as shown in the picture below.

**Note:** There is still water inside the pump.

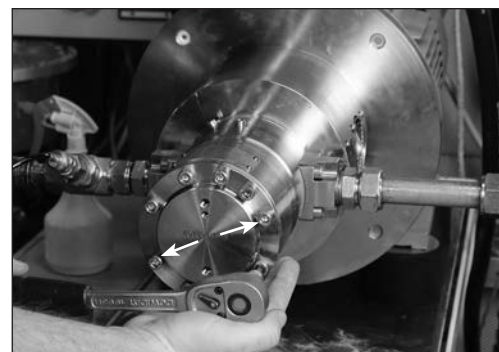

3. Unscrew the remaining screws.



4. Remove the flange. Remove pin or ensure it stays in place. Ensure not to scratch the swash plate surface.



5. While holding the retainer plate with one hand, carefully remove the pistons one by one with the other hand.



6. **WARNING:**  
Ensure that the piston shoes and the piston surfaces are not damaged during removal. It is recommended to place the pistons upside down on an even and clean base/surface.



7. Remove retainer plate and ball.



8. Remove guide and spring.



9. Inspect the piston liners.

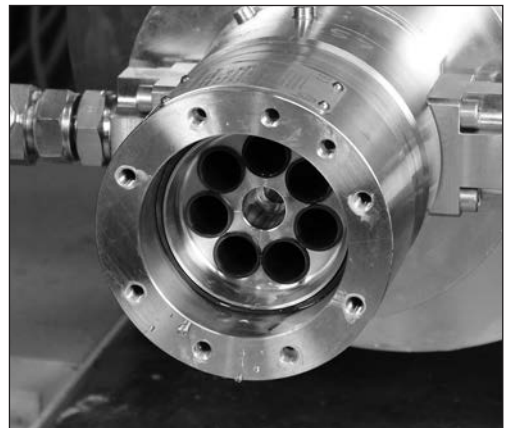

10. Replace any worn parts.

**8.2 Assembling**

1. Ensure the liner and the end of cylinder barrel are wetted.

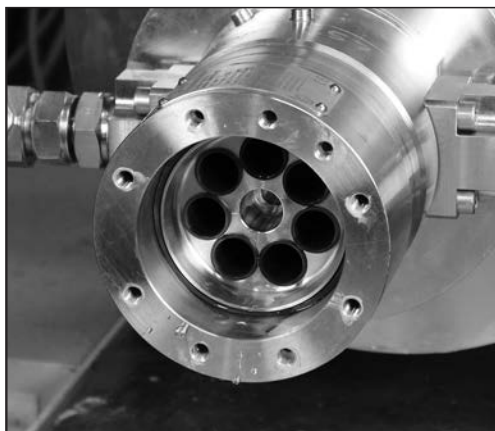

2. Place the spring.

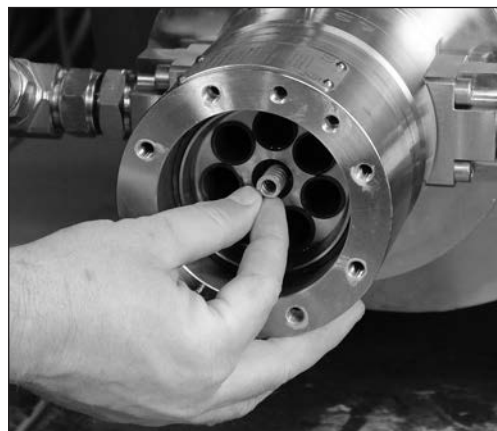

3. Place the guide.



4. Place the ball on the retainer plate.

**WARNING!**  
Ensure right assembling and placement of the retainer plate. See item 16, page 11.



5. Place the retainer plate and hold it with one hand. Insert the pistons one by one with the other hand.

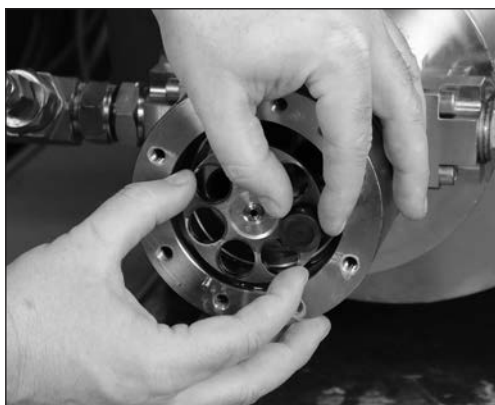

6. Wet the pistons.



7. Replace the O-ring and mount the flange. Ensure the guide pin is mounted.



8. Mount two screws as shown below and tighten them.



9. Mount the remaining bolts and cross tighten them to a torque of  $30 \text{ Nm} \pm 3 \text{ Nm}$ .

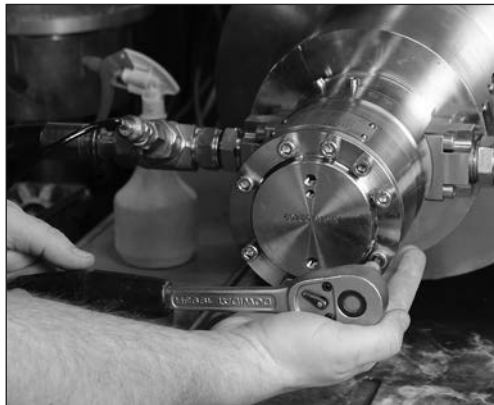

10. Connect the pump to the rest of the system.

11. Bleed the pump before starting it.

9. Exploded view  
APP S 674 3.0-3.5  
pumps

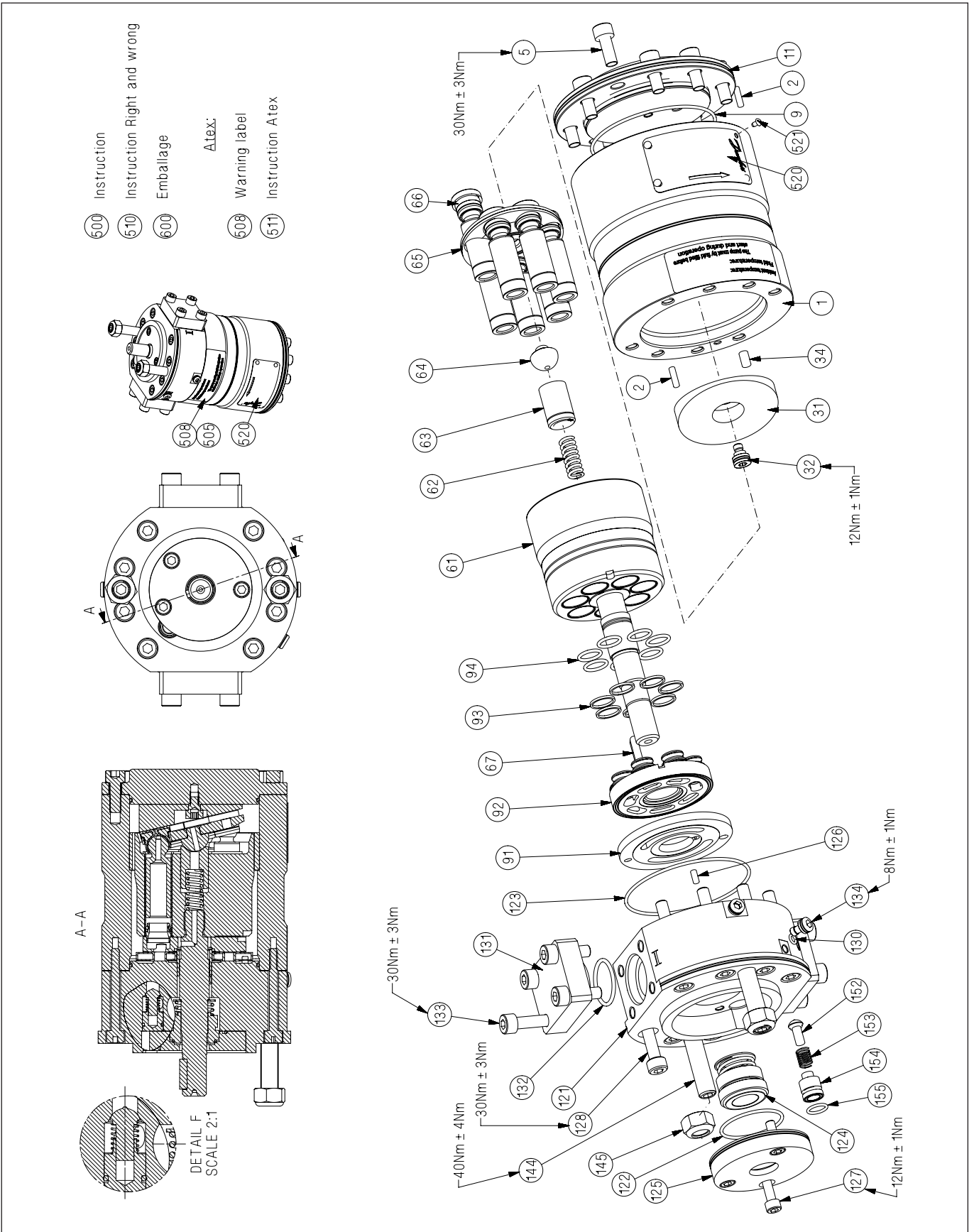

**10. When should the pistons be replaced**

This section provides guidance on, how to determine whether the parts of the pump are worn and should be replaced. In case of doubt - the pistons must be replaced. The pictures below are meant as a guideline for evaluating the wear of the sliding surface.

**Note: If the pistons break down, the pump will suffer a disastrous breakdown.**

Picture 1:  
Cavitation of the piston shoes.  
New inspection is required in 3,000-4,000 hours.



Picture 2:  
Cavitation of the piston shoes.  
All pistons must be replaced within the next 500-1,000 hours.



Picture 3:  
Cavitation of the piston shoes.  
All pistons must be replaced within the next 100-200 hours.



Picture 4:  
Abrasive wear of the piston shoes.  
All pistons must be replaced immediately.

