

User manual

Installation, Operation and Maintenance Manual APP pumps (APP 21-43)



APP 21-43

Table of Contents

Validity	4
EU Declaration of Conformity	5
1. Introduction	6
1.1 General	6
1.2 Symbols	6
1.3 Manufacturer and customer service address	7
2. Safety	7
2.1 General information	7
2.2 Preferred system design	7
2.3 Commissioning and servicing the unit	8
2.4 Adhere to the following important points	8
2.5 In case of doubt	8
3. Technical data	8
3.1 Approved applications and operational limits for the pumps	8
3.2 Application range	8
3.3 Electric motor data	8
3.4 Noise and vibration	8
3.5 Dimension drawings	8
3.6 Space requirement	8
3.7 Filtration	9
3.8 Properties of water	9
3.9 Air bubbles	9
3.10 Chemicals	9
4. Arrival inspection, transportation, handling, lifting and storage	9
4.1 Arrival inspection	9
4.2 Warning	9
4.3 General safety information	9
4.4 Transport and handling	9
4.5 Return to supplier	10
4.6 Storage	10
5. Installation and commissioning	11
5.1 Important dimensions	11
5.2 Cleanliness	11
5.3 Fluid temperature	11
5.4 Electrical data	11
5.5 Local regulations	11
5.6 Pre mounting checklist, based on Danfoss preferred system design	11
5.7 Lifting and positioning	12
5.8 Mount the different equipment	12
5.9 Electrics	12
5.10 Instrumentation	12
5.11 Connections	12
5.12 Ensure free flow	13
5.13 Verify setting of safety/relief valves	13
5.14 Flush the pump	13
5.15 Bleed and remove air from the pump	13
5.16 Verify direction of rotation	13
5.17 Commissioning	13
5.18 Check the filter condition	13
5.19 Instruct operator and maintenance personnel	13
6. Operation of pump unit	14
6.1 General safety information	14
6.2 What to listen and look for	14

7.	Maintenance and service of the pump unit	14
7.1	General safety information	14
7.2	Service and inspection interval for the pump	14
7.3	Shut down of the system	14
7.4	Disassembling and assembling the pump unit	15
7.5	Assembling the pump unit	15
7.6	Procedure for mounting the pump onto the electric motor	15
7.7	Getting the pump unit back into operation	15
7.8	Storage of the pump	15
8.	Troubleshooting and scrapping criteria	16
8.1	General safety information	16
8.2	Operational conditions which can cause pump failures	16
8.3	Mechanical failure	16
8.4	Electrical failure	16
8.5	Responsibility	16
8.6	Scrapping criteria	16
	Subject index	18

Appendices for Installation, Operation and Maintenance Manual

1.	Data sheet for APP 21-43 pumps (521B0852)	3
2.	APP pump instruction APP 21-43 (180R9133)	17
3.	IOM Electric motors (180R9230)	27
4.	Recommended service intervals for APP pumps (180R9199)	33
5.	APP parts list (521B0941)	37
6.	Trouble shooting guide	45
7.	Right and wrong (180R9042)	55

Validity

This manual is valid for APP pumps with the following code numbers/serial numbers:

APP 21/1200	Code no.	180B3051
	Serial no.	05
APP 21/1500	Code no.	180B3052
	Serial no.	03
APP 24/1200	Code no.	180B3054
	Serial no.	05
APP 24/1500	Code no.	180B3055
	Serial no.	02
APP 26/1200	Code no.	180B3056
	Serial no.	05
APP 26/1500	Code no.	180B3057
	Serial no.	05
APP 30/1200	Code no.	180B3060
	Serial no.	03
APP 30/1500	Code no.	180B3062
	Serial no.	02
APP 38/1500	Code no.	180B3071
	Serial no.	02
APP 43/1700	Code no.	180B3072
	Serial no.	02

EC Declaration of Conformity

Danfoss A/S

Danfoss High Pressure Pumps
 Nordborgvej 81
 6430 Nordborg
 Denmark

EG-Konformitätserklärung gemäß EG-Richtlinie 2006/42/EG	EC Declaration of Conformity according to Directive 2006/42/EC	Déclaration de conformité CE conformément à la Directive 2006/42/CE
Hiermit erklären wir, dass die Maschine gemäß 2006/42/EG entwickelt ist.	We hereby declare that the machine is designed according to the directive 2006/42/EC.	Par la présente, nous déclarons que la machine est conçue conformément à la Directive 2006/42/CE.
Beschreibung der Maschine Hochdruck-Pumpe	Machine description High pressure pump	Description de la machine Pompe haute pression
Maschinentyp APP 0.6-1.0 / APP 1.5-3.5 / APP 5.1-10.2 / APP 11-13 / APP 16-22 / APP 21-43	Machine designation APP 0.6-1.0 / APP 1.5-3.5 / APP 5.1-10.2 / APP 11-13 / APP 16-22 / APP 21-43	Type de machine APP 0.6-1.0 / APP 1.5-3.5 / APP 5.1-10.2 / APP 11-13 / APP 16-22 / APP 21-43
Seriennummer N/A	Serial number N/A	Numéro de série N/A
Technisches Dossier, Kontaktperson Leiter Qualitätsabteilung	Technical dossier, Contact person Manager Quality Department	Personne de contact pour le dossier technique Manager département qualité
Angewandte harmonisierte Normen DS/EN ISO 12100: 2011	Used harmonised standards DS/EN ISO 12100: 2011	Normes harmonisées appliquées DS/EN ISO 12100: 2011

Hersteller-Unterschrift / Titel:

Manufacturer's signature / Title:

Signature du fabricant / Titre:



2013-05-27
Datum

2013-05-27
Date

2013-05-27
Date

1. Introduction

1.1 General

The APP pumps and pump units are manufactured by Danfoss A/S, and are sold and marketed by a net of authorized distributors world wide.

This manual contains the necessary instructions for the installation, operation and service of the pumps used in a Sea Water Reverse Osmosis (SWRO) system or Brackish Water Reverse Osmosis (BWRO) system.

In case the pump delivered is ATEX certified, the additional ATEX instruction must also be read.

The APP pumps must not be used for other purposes than those recommended and specified without first consulting your local pump distributor.



Use of the pump in other applications that are not suitable for the pump unit can cause damages to the pump unit, with risk of personal injury.



All personnel being responsible for operation and maintenance of the pump unit must read and fully understand these instructions, especially the section "Safety", before:

- Transportation of the pump unit
- Lifting the unit
- Installing the pump unit
- Connecting the pump unit to the water system
- Connecting the electric motor and instrumentation
- Commissioning the unit
- Servicing the pump unit, mechanical and electrical parts
- Decommissioning the pump unit

The pump must always be installed and used in accordance with existing national/local sanitary, safety regulations and laws.

It is the responsibility of the safety officer or the chief operator to assure compliance with all local regulations that are not taken into account in this manual.



Changing the pumps' or pump units' operational limits and hardware:

- Changes to the delivered pump or motor pump unit may only be done with a written approval from Danfoss High Pressure Pumps.
- Operation outside the Danfoss specifications requires a written approval from Danfoss High Pressure Pumps.

- If any changes are made without written approval the warranty will automatically become void.

It is important that these instructions are always available to the personnel concerned.

1.2 Symbols



Indicates something to be noted by the reader



Indicates a situation which will or could result in damage to the pump and its function



Indicates a situation which will or could result in personal injury and/or damage to the pump



Electrical hazard - Indicates a high-voltage warning



Safety glasses required



Hearing protection required



Safety shoes required



Safety helmet required



Protective garments must be worn

Protective garments must be worn



Danger Hot Do not touch

Danger HOT. Do not touch



Electrical hazard

Electrical hazard

1.3 Manufacturer and customer service address

Danfoss A/S
Danfoss High Pressure Pumps
RO Solutions
 Nordborgvej 81, D25
 DK-6430 Nordborg
 Denmark

Telephone: +45 7488 4024
 Fax: +45 7445 3831
 Email: ro-solutions@danfoss.com
 Homepage: www.ro-solutions.com

Your local Danfoss pump distributor can be found on our homepage.

Data sheets and instructions on all accessories are available on www.ro-solutions.danfoss.com

EC Declaration of Conformity can be found on page 5.

2. Safety



2.1 General information

Dangers that can arise from not following the instructions:

When the pump or pump unit is managed by untrained personnel, there is a danger of:

- Death or fatal injuries
- Costly damages and claims



Electrical hazard

All electrical installation work must only be carried out by authorized personnel in accordance with EN60204-1 and/or local regulations.

It is recommended to install a lockable circuit breaker to avoid inadvertent starting and/or electrical hazard. The lockable circuit breaker must be used during installation, operation and maintenance.

It is recommended to place a local safety switch nearby the pump, enabling service personnel to cut power for the electric motor.

Protect the motor and other electrical equipment from overloads with suitable equipment.

In case the pump delivered is ATEX certified, the additional ATEX instruction must also be read.



Protective garments must be worn



Always wear suitable safety clothing when handling the pump.

When working near the pump system, safety shoes, safety glasses, hearing protection and safety helmet must always be worn.



Danger Hot
Do not touch

Under certain operational conditions the surface of the pump can be above 60°C / 140°F. Under these conditions the pump must be labelled with a "Danger Hot" sign.

When using an electric motor, the motor must always be supplied with adequate cooling ventilation.

When using an electric motor together with a VFD, the motor must be designed for operation with a VFD.

VFD operation may increase the temperature inside the electric motor if the motor is not designed for VFD operation. This can damage the motor and cause unintended breakdown.



Before start-up, the settings for all protective devices, such as sensors/switches and safety valves must be verified and free flow from safety valves must be ensured.



All pipe and hose connections must be stress-free mounted, securely fastened to the pump and well supported. Improper installation will or can result in personal injury and/or damage to the pump.

Use of this manual does not relieve operation and maintenance personnel of the responsibility of applying good judgment when operating and maintaining the pump and its components.

2.2 Preferred system design

Danfoss recommends to build systems with a high degree of safety. Danfoss preferred system design and P&ID are found in appendix 1, Data sheet, and appendix 2, Instruction.



It is always the system builders' responsibility that the system design does not cause any kind of hazard and is adapted to local regulations and standards.

Proper installation, proper start up and shut-down devices as well as high-pressure protection equipment is essential.

2.3 Commissioning and servicing the unit

It is recommended that commissioning and servicing are carried out by a minimum of two people, where one is acting as a supervisor.

2.4 Adhere to the following important points

- Before using the pump/pump unit it is very important to read and understand this user manual.

- Do not try to lift the pump unit manually; most of the pumps weigh more than 20 kilos, see specific weight for the pump in the appendix 1, Data sheet.
- Always bleed the pump prior to initial start-up.
- Do not mount the pump without the bell housing and a flexible coupling.
- Do not try to start the unit before the system components are mounted, bled and adjusted.
- Flush the system thoroughly before connecting the pump or pump unit.
- Check rotation direction of the motor before mounting the pump.

2.5 In case of doubt

Please contact Danfoss A/S in case of doubt. Contact information is listed in section 1.3, Manufacturer and customer service address.

3. Technical data



3.1 Approved applications and operational limits for the pumps

The pump and the pump units are designed for the use in a Sea Water Reverse Osmosis (SWRO) or Brackish Water Reverse Osmosis (BWRO) systems and Brackish Water Reverse Osmosis (BWRO) system.

The APP pumps must not be used for other purposes than those recommended and specified without first consulting your local pump distributor.



Use of the pump in other applications not suitable for the pump unit can cause damages to the pump unit, with risk of personal injury.

For system integration of the pump, please see appendix 1, Data sheet and appendix 2, Instruction.

3.2 Application range

See appendix 1, Data sheet.

3.3 Electric motor data

See recommended motor in appendix 1, Data sheet or appendix 3, IOM for motors. The motors mentioned are the most common used motors by Danfoss High Pressure Pumps.

3.4 Noise and vibration

Noise level for a pump unit with a "standard" motor measured according to EN ISO 3744: 2010, see appendix 1, Data sheet. Possibilities to reduce noise and vibration are described in the same Data sheet.

3.5 Dimension drawings

Dimensions of the different pumps can be found in appendix 1, Data sheet.

3.6 Space requirement

When doing service or replacing the complete pump unit, it is recommended to have sufficient space available around the pump in order to ensure easy access. Sufficient space means at least 1 meter/40 inches around the pump. When working with high pressures, it is important to have the right space available around the pump as stated in the safety requirements.



3.7 Filtration

(10µm absolute [$\beta_{10} \geq 5000$])
 Requirements are specified in appendix 1, Data sheet and in appendix 2, Instruction.

Danfoss recommends not to build a filter bypass function or to use filters with an integrated bypass. If the above recommendation is not followed the warranty for the pump will automatically become void.

It should be possible to monitor the condition of the filter via the differential/delta pressure across the filter.

Using insufficient filtration or a filter bypass can cause a failure or decreased service life of the pump.

3.8 Properties of water

It is recommended NOT to use the pumps in feed water concentrations higher than 50,000 ppm TDS without consulting your local Danfoss pump distributor.



3.9 Air bubbles

Large bubbles in a pressurised RO system can result in damage to piping, equipment and the pump.

All air must be bled from both the low-pressure and high-pressure side before the RO system is pressurised. Special consideration should be given in order to minimize air bubbles in the feed flow. Air bubbles can cause cavitation.



3.10 Chemicals

The pump should not be exposed to any chemicals as it can result in damage to piping, equipment and internal parts in the pump.

4. Arrival inspection, transportation, handling, lifting and storage

4.1 Arrival inspection

The pump is packed in a cardboard or wood box with plugs in the port connections to protect the pumps from damage during transportation.

When the shipment has arrived it is important to check the pump for any damages. The name plate/type designation must be in accordance with the delivery note and your order.

In case of damage and/or missing parts, a report should be documented and presented to the carrier at once.



4.2 Warning

Before any lifting operation is performed, environmental conditions must be taken into consideration (Ex-rated areas, wind speed, wet/dry conditions, lifting height, etc.).

4.3 General safety information

Personnel involved in lifting and transporting the equipment (see Safety, chapter 2) must be trained in handling and in safety procedures for lifting heavy loads. Many of the pumps and pump units weigh more than 20 kilos, which requires lifting slings and suitable lifting devices; e.g. an overhead crane or industrial truck to be used as minimum.

4.4 Transport and handling

Small pumps which have a weight below 20 kilos (weight can be found in appendix 1, Data sheet), can be handled by hand if they are not mounted together with an electric motor. The weight of a small pump with a motor will be above 20 kilos.

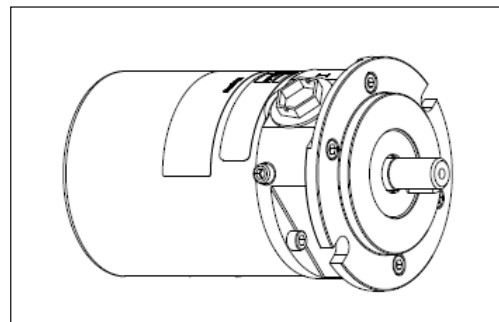
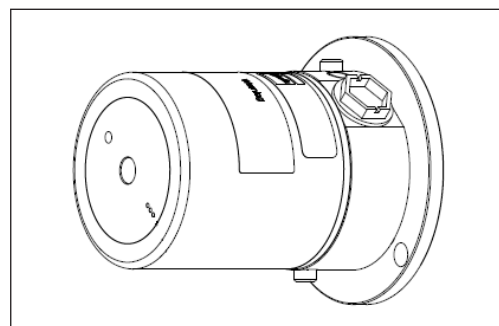

Pumps which have a weight above 20 kilos (see appendix 1, Data sheet) must be handled by using lifting eyes and slings.

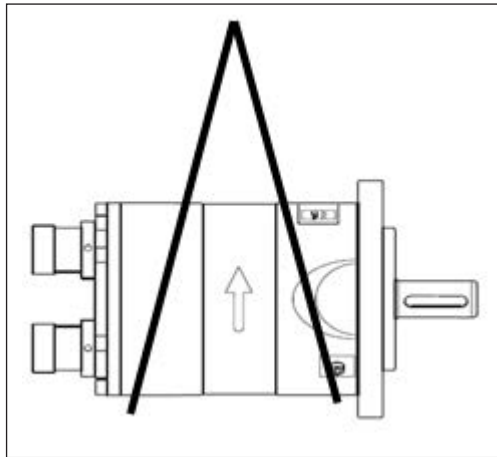
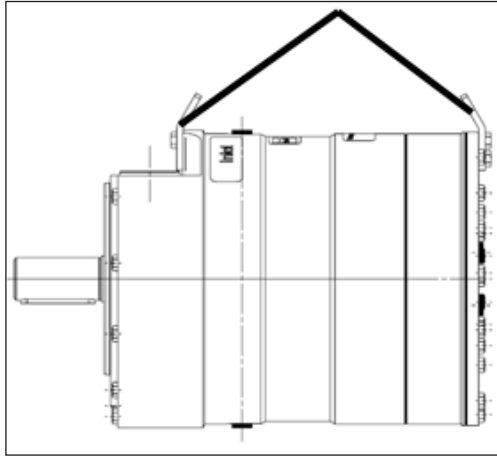

Never use only one sling and make sure the slings does not slip off the pump.

When the pump is mounted together with an electric motor, the pump unit always weigh more than 20 kilos and must be handled by using slings around the pump unit.

See below examples of where to/not to attach the lifting slings on the pump unit:

Correct lifting with 2 separate slings:

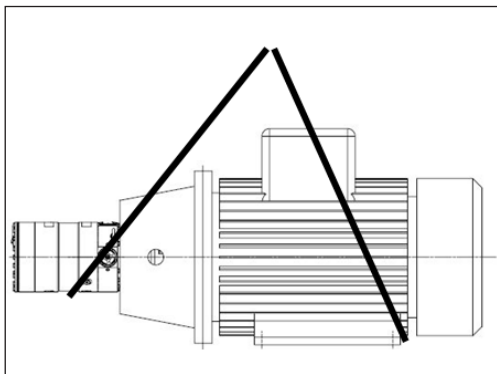

Wrong lifting:

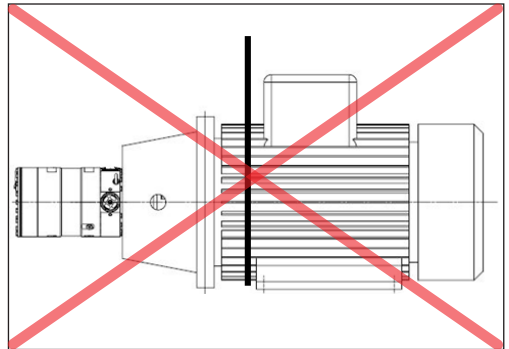
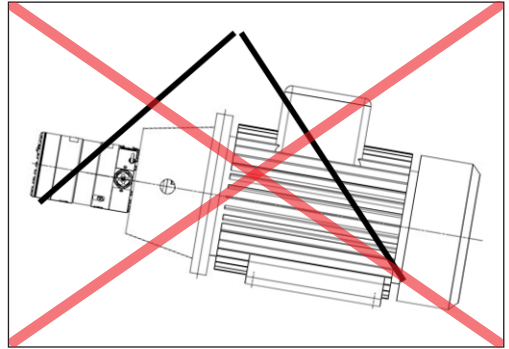

When lifting the pump unit, one sling must be attached to the electric motor and one sling around the pump.

Some motors and pumps have specific lifting eyes.

**Do not use connections/nozzles for lifting!
Do not use only one sling!**

Make sure that the unit/load is balanced before lifting. The centre of the mass varies from pump/pump unit size to pump/pump unit.

How to mount the pump and the electric motor correctly, see appendix 1, Data sheet or appendix 2, Instruction.



Incorrect lifting can result in personal injury and/or damage to the pump unit, see appendix 2, Instruction.

4.5 Return to supplier

Please see maintenance chapter 7.

4.6 Storage

Each pump is tested before shipment, and will therefore contain water. For storage temperature and frost protection see appendix 2, Instruction.

The pumps are NOT delivered frost protected from the factory.

5. Installation and commissioning



5.1 Important dimensions

Physical dimensions and connections of the pump unit are described in appendix 1, Data sheet.



5.2 Cleanliness

It is very important that the tubes and pipes are **completely clean**: no dirt, chips or burrs are allowed. Flush all piping before connecting the high-pressure pump to ensure the system is clean. Internal surfaces of the piping must not be corroded. If dirt or rust is not removed, the pump and the valves can be damaged. In worst case the pump can be damaged beyond repair!



5.3 Fluid temperature

Before start-up, the fluid and pump housing temperature must be within the specified temperature range listed see appendix 1, Data sheet.

5.4 Electrical data

Check voltage, current frequency and rated power on the electric motor and VFD settings on the name plate placed on both the motor and the VFD.



5.5 Local regulations

Commissioning must always be done in accordance with valid regulations and local standards.

Schematic 1: Recommended system design

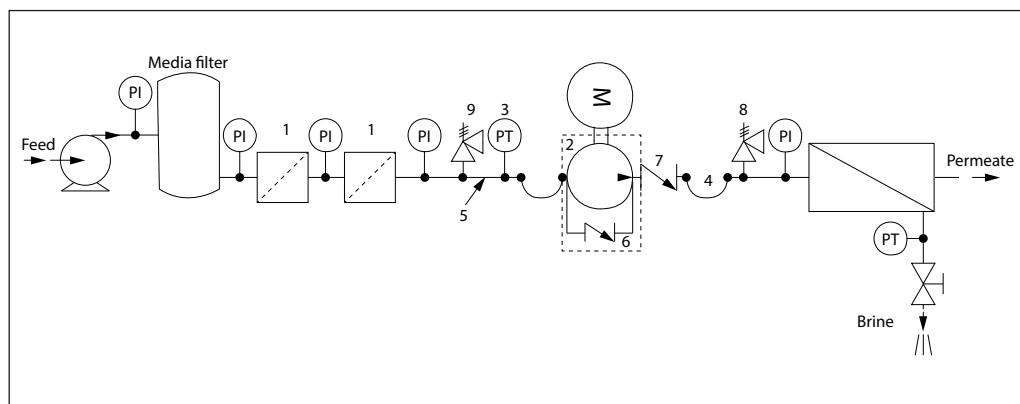

5.6 Pre mounting checklist, based on Danfoss preferred system design

Table 1: Check points when assembling and commissioning system

	Check points	Comment	OK ?
CP1	Ensure that the environmental conditions are safe.	See Arrival inspection, transportation, handling, lifting and storage, chapter 4.	
CP2	Minimum and maximum start-up temperature for fluid and pump.	See Data sheet or Instruction, appendices 1 and 2.	
CP3	Filtration condition (10 µm absolute ($\beta_{10} \geq 5000$))	See Danfoss requirements in Data sheet and Instruction, appendices 1 and 2	
CP4	Power supply for electric motor and VFD.	See Data sheet for the used motor and VFD.	
CP5	Safety circuit / breaker must be sized for the motor and environment (corrosion and humidity)	See Data sheet for the used safety circuit.	
CP6	Bolts and screws must conform to environmental conditions as well as fluid and torque requirements.		
CP7	Instrumentation, pressure switch should be designed to conform to the environment (corrosion and humidity).	See Data sheet for the used equipment.	
CP8	Check the factory settings of the safety/relief valves or pressure relief valves (8 & 9).	See Data sheets for the used valves.	
CP9	Check the settings of the pressure transmitter/switch (3) set at min. inlet pressure.	See Data sheet or Instruction, appendices 1 and 2.	
CP10	Check that all pressure indicators (PI) are selected to be able to measure the system pressure range.	Scaling should at least be 1 Bar or more precise.	
CP11	Check coupling distance (air gab – movement of the spider)	3 – 5 mm	
CP12	Check correct connections on the pump (in & outlet)		
CP13	Check piping for possible air gaps.		



5.7 Lifting and positioning

Lift the pump unit onto base (Remember vibration dampeners, if needed). Fasten the motor to the base.

See also chapter 4, Arrival inspection, transportation, handling, lifting and storage.

5.8 Mount the different equipment

(connections, pipes, tubes, check and safety/relief valves, etc.)

- The hard piping and flexible hoses used, must be of proper design and must be installed in accordance with the manufacturer's recommendations. (see also Data sheet for Hose and hose fittings and Instruction for Assembling Hose kit - both available on www.ro-solutions.danfoss.com).
- Misalignment of the hard pipes may give unintended stress on the pump port connections and may damage the pump.
- Prevent excessive external pipe load.
- Do not connect piping by applying external force (use of wrenches, crane, etc.) Piping must be aligned without residual stress.
- Do not mount expansion joints so that their force applies internal pressure on the pump connections.

5.9 Electrics

All electrical installation work must be carried out by authorized personnel in accordance with EN60204-1 and/or local regulations. (see also Safety, chapter 2)

Turn off the safety circuit breaker and lock it.

Mount the power cable on the electric motor.

If a VFD is used, adjust the protective motor switch/VFD to the current limits found on the name plate of the electric motor.

5.10 Instrumentation

The pressure switch/sensor should be mounted as close to the pump as possible. It is recommended to test the pressure/sensor switch via an instrumentation manifold.

Mount the pressure switch/sensors according to the manufacturer's instructions.

5.11 Connections

Mount and tighten connections and check valve(s) as specified.

5.12 Ensure free flow

Ensure free flow from the safety/relief valves 8 and 9 (figure 1, item 5.6). A blocked safety/relief valve can cause excessive build-up of pressure and thereby cause dangerous situations and damage to the whole system.

5.13 Verify setting of safety/relief valves

Make sure, the safety/relief valves 8 and 9 are placed correctly.

Check the pressure settings on the name plates of the safety/relief valves. If they are within specifications, you can continue.

5.14 Flush the pump

Fully open the pressure valve at the brine outlet.

Close all the bleeding and draining plugs on the high-pressure pump.

Start the feed pump and ensure free flow to the high-pressure pump.

5.15 Bleed and remove air from the pump

Open the bleeding plugs. Keep the plugs open until the high-pressure pump is bled.

5.16 Verify direction of rotation

The direction of rotation must always follow the arrow. The arrow is placed on the pump or pump unit.

Check the direction of rotation before mounting the pump.

Unlock the safety circuit breaker. Start the motor for 1 second and observe the direction of rotation either looking at the fan of the motor or the coupling through the inspection hole in the bell housings (not available on all bell housings). If the motor is turning the wrong direction, switch two phases in the connection box of the motor or reprogram the direction in VFD.

When the motor is turning in the right direction, the pump can be mounted.

5.17 Commissioning

- Close all the bleeding and draining plugs.
- Open the pressure valve at the brine site.
- Switch the safety circuit breaker on for both motor(s) and VFD(s).
- Start the feed pump.
- Start the high-pressure pump.
- If a VFD or a soft starter is used a ramp up time of minimum 10 seconds is required to avoid damage of the pump.
- Monitor the inlet and outlet pressure of the high-pressure pump and look for leakages.
- Check the function of the pressure indicators by slowly closing the valves. The pump unit should stop when the minimum inlet pressure and maximum outlet pressure has been reached.
- Adjust the pressures to the specified inlet and outlet pressure for the system and let the pump unit run until the electric motor and pump temperature is stable.
- If the system is running within the system design limits, the system is released for operation.



5.18 Check the filter condition

Evaluate contamination found in filter, replace filter elements, if necessary.



5.19 Instruct operator and maintenance personnel

Before using the pump/pump unit, the personnel must be instructed in using the pump/pump unit, its function, components, documentation and safety.

Danfoss offers commissioning and service at system manufacturer's location. Rate quotes are offered upon request.

6. Operation of pump unit



6.1 General safety information

Before inspecting the pump unit, read the Safety chapter 2 in this user manual.

6.2 What to listen and look for

If one or more of the following examples are observed, please act as indicated:

- A) Loose bolts – check all bolts and, if necessary, contact the maintenance department in order to have all bolts tightened to the specified torque(s).
- B) Leakage – if a small leakage from the bell housing is observed. Contact the maintenance department.
- C) Leakage – if there is a large leak, the unit should be stopped immediately. Contact the maintenance department.
- D) High frequency tones – safety/relief valves are either damaged or running very close to their design pressure, stop the unit immediately. Contact the maintenance department.
- E) Increased noise or vibration – requires the unit to be stopped immediately. Contact the maintenance department.
- F) Very high temperatures – may indicate that one or more parts are damaged inside the pump. The pump must be stopped immediately and inspected before it is restarted. Contact the maintenance department.

- G) Drop in flow and/or pressure – may indicate wear on one or more parts inside the pump. The pump must be stopped immediately and inspected before it is restarted. Contact the maintenance department.
- H) Other observations or troubles, please see appendix 7, Right and Wrong or appendix 6, the Trouble shooting guide. Both appendices give good advises regarding design, installation, wiring and troubleshooting. See also service and warranty section in appendix 1, Data sheet and appendix 2, Instruction.

If the pump is not stopped for inspection as recommended, it can lead to damage of the pump or break-down. See also service and warranty section in the appendix 1, Data sheet, in appendix 2, Instruction or appendix 4, Instruction for recommended service intervals.

Danfoss offers service of the pump at the system manufacturer's location as well as we offer training in how to service the pump. Quotes are offered upon request.

Danfoss recommends simultaneously to check the filter and membrane condition and to evaluate contamination; filter and membrane elements must be replaced if necessary.

7. Maintenance and service of the pump unit



7.1 General safety information

Before servicing the pump unit, it is necessary to read and understand this user manual, especially the Safety, chapter 2. Remember to wear suitable safety equipment according to Safety, chapter 2.

7.2 Service and inspection interval for the pump

Maintenance and service intervals are depending on the cleanliness level of the water, hydraulic load and temperature of the pump unit. The most important parameter is the filtration of the water.

See the section Service and warranty in the appendix 1, Data sheet, in appendix 2, Instruction and appendix 4, Instruction for recommended service intervals.

For spare parts and service tools, please see appendix 3, Parts list.

Danfoss offers service of the pump at the system manufacturer's location and training in how to service the pump. Quotes are offered upon request.

7.3 Shut down of the system

- A) Open the pressure valves at the brine site to release the pressure.
- B) Stop the high-pressure pump.
- C) Stop the feed pump.
- D) Switch off the safety circuit breaker for both the high-pressure pump, feed pump and VFD and lock them. Only personnel servicing the pump unit should be able to unlock/activate the switch again.
- E) Open bleeding and drain plugs. Wait until the pump and system are emptied for water.



- F) Slowly unscrew and remove the bolts and gaskets from the inlet/outlet hoses or pipes, be careful about jets of water. Beware that the system can be pressurized!
- G) Attach the lifting equipment to the pump unit. For instructions on lifting the complete pump unit, see chapter 4, Arrival inspection, transportation, handling, lifting and storage.
- H) For the small pumps, unscrew the bolts holding the pump to the bell housing. For the bigger pumps, unscrew the bolts/nuts from the pump and bell housing to the motor. Afterwards unscrew the bolts/nuts holding the pump and bell housing.
- I) Carefully pull the pump out of the bell housing by using lifting equipment, if necessary.
- J) Hold the pump in different positions above a drip tray; this should allow most of the water trapped in the pump to drain. Clean and dry the pump surface and plug the bleeding and draining plugs.
- K) Move the pump to a clean and safe location where the pump can be inspected/ serviced.

7.4 Disassembling and assembling the pump unit

- A) Remove all connections from the pump.
- B) Disassemble the pump according to the Disassembling and Assembling Instruction (available at www.ro-solutions.danfoss.com)

Clean all parts and surfaces with a fluid compatible with the materials found in the pump. Wipe the parts clean and dry with a lint-free clothing.
- C) Inspect all parts including shaft seal and if necessary, replace them; see appendix 3, Parts list.
- D) If the pump is going to be returned to Danfoss for repair or a warranty claim, it is important to contact Danfoss in order to receive a return number and a form to fill out with product information. A copy of the form together with contact information and reason for returning should be sent to the email address on the form. The same documents should be attached to the shipment.

Product information (see label on product) Only 1 product on each report.		
Product type:	Code number	Serial number
Operational conditions		
Application:	Inlet pressure:	Rpm.(pump/motor only):
Hours of operation:	Outlet pressure:	Number of duty cycles (valves only)
Filtration (µ, absolute/nominal) :	Flow:	Water temperature:
Water type:	TDS	Pumps in parallel (yes/no):

Returns without a return number will be rejected !!!

7.5 Assembling the pump unit

Assemble the pump according to the Disassembling and Assembling Instruction (available at www.ro-solutions.danfoss.com).

7.6 Procedure for mounting the pump onto the electric motor



Mount the flexible coupling and bell housing according to appendix 2, Instruction.

7.7 Getting the pump unit back into operation

Find instructions of how to put the pump unit back into operation in chapter 4, Arrival inspection, transportation, handling, lifting and storage and Installation and commissioning, chapter 5.

7.8 Storage of the pump

If the pump has to be shut down for a longer period, instructions can be found in appendix 2, Instruction.

8. Troubleshooting and scrapping criteria



8.1 General safety information

Before inspecting the pump unit, it is necessary to read and understand this user manual, especially the Safety chapter 2.

Remember to wear suitable safety equipment according to Safety chapter 2.

8.2 Operational conditions which can cause pump failures

The following conditions can cause a pump failure :

- The pump is running dry.
- The inlet pressure is too high.
- The inlet pressure is too low.
- The temperature of the fluid is too high.
- The ambient temperature is too high.
- The pump is running against a blocked port/closed manual valve.
- The pump is operating at a pressure out of specification.
- The pump is running with a non-specified/ approved fluid.
- The pump is running in the wrong direction.
- The filtration is insufficient.
- The pump is not being serviced according to Danfoss specifications (end of life).
- There is excessive mechanical load on the shaft coupling and piping.



8.3 Mechanical failure

If the pump is running dry, the temperature will quickly increase which can cause burns.

If there is any leakage at start-up or during operation, a high pressure jet can cause eye or skin damage.

Leakage can result in flooding, which can cause slipping, tripping or falling.

If water is leaking into the electric motor; it can cause electric shock, fire, short circuit or even death. When mounting the pump vertically always mount the motor above the pump to avoid water leaking into the electric motor.



8.4 Electrical failure

If the wiring of the electric motor is incorrect or the ground connection is missing, it can cause electric shock, burn damages, fire or even death.

If a VFD is used and wrongly programmed, it can damage the pump and lead to high temperatures or other dangers.

All electrical installation must be carried out by authorized personnel in accordance with EN60204-1 and/or local regulations.

8.5 Responsibility

Danfoss takes no responsibility for any abnormal injuries, risks or damages that could arise caused by abnormal conditions, vibrations, corrosion, abrasives, foreign objects or excessive temperatures and shall not be liable for any consequential or incidental damages.

8.6 Scrapping criteria

Whether the pump can be repaired or need to be scrapped, depends on in which conditions the internal parts are, or how damaged the whole unit is. Please use appendix 6, Trouble shooting guide as guideline or send the pump to Danfoss headquarter in Denmark for evaluation.

For other observations or troubles, please see appendix 7, Right and Wrong which gives good advises regarding design, installation, wiring and troubleshooting.

In case the pump needs to be scrapped, please follow your local environmental rules.

Subject index

<p>A Address 7, 8, 15 Air bubbles 9 Appendix 7, 8, 9, 10, 11, 14, 15, 16 Application range 8 Approval 6 Arrival 9, 12, 15 Assembling 12, 15</p> <p>B Bleed 8, 9, 13, 15</p> <p>C Checklist 11 Check points 12 Chemicals 9 Cleanliness 11, 14 Commissioning 6, 8, 11, 12, 13, 15, 16 Connections 7, 9, 10, 11, 12, 15 Coupling 8, 12, 13, 15, 16</p> <p>D Danger 6, 7, 13, 16 Data sheet 7, 8, 9, 10, 11, 12, 14 Declaration of Conformity 5, 7 Design 7, 8, 9, 11, 12, 13, 14, 16 Distributor 6, 7, 8, 9 Dimensions 8, 11 Disassembling 15</p> <p>E EC Declaration of Conformity 5, 7 Electric motor 6, 7, 8, 9, 10, 11, 12, 13, 15, 16 Electrical failure 16 Electrical hazard 6, 7 Electrics 12</p> <p>F Failure 8, 16 Filter condition 13 Filtration 9, 12, 14, 16 Flow 7, 9, 13, 14 Fluid 11, 12, 15, 16 Flush 8, 11, 13</p>	<p>G General information 7 Guideline 16</p> <p>H Handling 7, 9, 12, 15</p> <p>I Inspection 13, 14 Installation 6, 7, 8, 11, 12, 14, 15, 16 Instruction 6, 7, 8, 9, 10, 12, 14, 15 Instrumentation 6, 12 Introduction 6</p> <p>M Maintenance 6, 7, 10, 13, 14 Mechanical failure 16 Mounting 8, 11, 13, 15</p> <p>N Name plate 9, 11, 12, 13 Noise 8, 14</p> <p>L Leaking 16 Lifting 6, 9, 10, 12, 15 Local regulations 6, 7, 8, 11, 12, 16</p> <p>O Operation 6, 7, 8, 9, 13, 14, 15, 16 Operational conditions 7, 16</p> <p>P Piping 9, 11, 12, 16 Positioning 12 Preferred system design 7, 11 Pre mounting 11 Protection 6, 7, 8, 10</p> <p>R Relief valve 12, 13, 14 Responsibility 6, 7, 8, 16 Return 10, 15 Rotation 8, 13</p>	<p>S Safety 6, 7, 8, 9, 12, 13, 14, 16 Safety valve 7 Scrapping criteria 16 Serial number 4 Servicing 6, 8, 14 Shut down 14, 15 Space requirement 8 Spare part 14 Start up 8 Storage 9, 10, 12, 15 Symbols 6 System 6, 7, 8, 9, 11, 12, 13, 14 Systems 7, 8</p> <p>T Table of Contents 2 Technical data 8 Temperature 7, 10, 11, 12, 13, 14, 16 Transportation 6, 9, 12, 15 Trouble shooting 14, 16</p> <p>V Valve 7, 11, 12, 13, 14, 16</p> <p>W Warning 6, 9</p>
---	--	--

Danfoss A/S
High Pressure Pumps
DK-6430 Nordborg
Denmark

Danfoss can accept no responsibility for possible errors in catalogues, brochures and other printed material. Danfoss reserves the right to alter its products without notice. This also applies to products already on order provided that such alterations can be made without subsequential changes being necessary in specifications already agreed. All trademarks in this material are property of the respective companies. Danfoss and the Danfoss logotype are trademarks of Danfoss A/S. All rights reserved.



User manual

Appendices for Installation, Operation and Maintenance Manual APP pumps (APP 21-43)



APP 21-43

Table of Contents

1.	Data sheet for APP 21-43 pumps (521B0852)	3
2.	APP pump instruction 21-43 (180R9133)	17
3.	IOM Electric motors (180R9230)	27
4.	Recommended service intervals (180R9199)	33
5.	APP parts list (521B0941)	37
6.	Trouble shooting guide	45
7.	Right and wrong (180R9042)	55



Data sheet

Data sheet APP 21-43



Table of Contents

- 1. General information
- 2. Benefits
- 3. Technical data
- 4. Variants
- 5. Flow at different rpm
- 6. Flushing valve
- 7. Power requirements
- 8. Temperature and corrosion
 - 8.1 Operation
 - 8.2 Storage
- 9. Noise level
- 10. Filtration
- 11. Dimensions
- 12. Dimensions, complete unit
- 13. Installation
 - 13.1 Mounting
 - 13.2 Open-ended system with direct water supply
 - 13.3 RO system with APP pump
- 14. Service
 - 14.1 Warranty
 - 14.2 Maintenance
 - 14.3 Repair

1. General information

APP 21-43 pumps are designed to supply low viscosity and corrosive fluids under high pressure, e.g. in seawater reverse osmosis filtration applications and for high pressure salt water pumping.

The pumps are based on the axial piston principle enabling a very light and compact design, and they are designed so that the

lubrication of the moving parts in the pumps is provided by the fluid itself. No oil lubrication is thus required.

The pumps are supplied with an integrated flushing valve that allows the salt water to flow from inlet to the outlet, when the pump is not running.

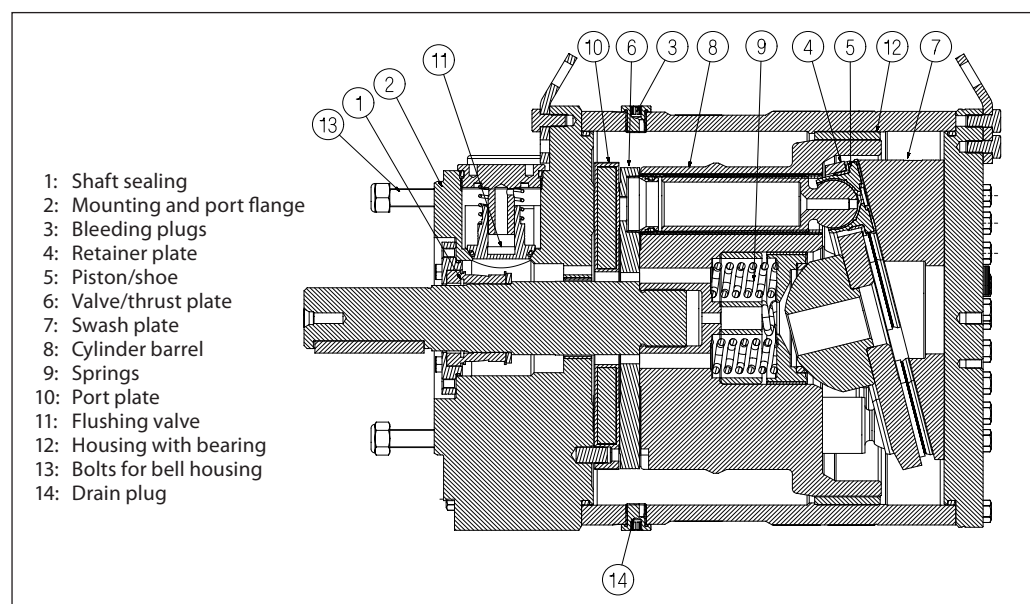

All parts included in the pumps are designed to provide long service life, i.e. long service life with a constantly high efficiency and minimum service required.

The pumps are fixed displacement pumps in which the flow is proportional to the number of revolutions of the input shaft and the pump displacement.

2. Benefits

- One of the smallest and lightest pumps on the market
- Can be powered by a combustion engine provided that a special coupling is used.
- Long service life / No preventive maintenance required in the warranty period.
- Generates insignificant pulsations in the pressure line.
- No oil lubricant required
- Integrated flushing valve
- All parts of the pump are made of non-corrosive materials, e.g. Duplex (EN1.4462/ UNS S31803-S32205) and Super Duplex (EN1.4410/UNS S32750) stainless steel and carbon reinforced PEEK
- High efficiency

3. Technical data

APP Pumps		APP 21 1200	APP 21 1500	APP 24 1200	APP 24 1500	APP 26 / 1200	APP 26 / 1500	APP 30 / 1200	APP 30 / 1500	APP 38 / 1500	APP 43 / 1700
Code number Standard		180B3051	180B3052	180B3054	180B3055	180B3056	180B3057	180B3060	180B3062	180B3071	180B3072
Geometric displacement	cm ³ /rpm	308	256	362	282	389	308	444	362	444	444
	in ³ /rpm	18.8	15.6	22.1	17.2	23.7	18.8	27.1	22.1	27.1	27.1
Rated flow at max. speed ¹⁾	m ³ /h	21.1	21.9	24.8	24.1	26.6	26.6	30.7	31.3	38.4	44.6
	gpm	92.9	96.4	109	106.2	117.1	117.4	135.1	137.7	168.9	196.4
Outlet min. pressure ²⁾	bar	30	30	30	30	30	30	30	30	30	30
	psi	435	435	435	435	435	435	435	435	435	435
Outlet max. pressure, continuous ³⁾	bar	80	80	80	80	80	80	80	80	80	70
	psi	1160	1160	1160	1160	1160	1160	1160	1160	1160	1015
Inlet min. pressure	bar	2	2	2	2	2	2	2	2	2	3
	psi	29	29	29	29	29	29	29	29	29	43
Inlet max. pressure, continuous	bar	5	5	5	5	5	5	5	5	5	5
	psi	72.5	72.5	72.5	72.5	72.5	72.5	72.5	72.5	72.5	72.5
Inlet max. pressure, peak	bar	10	10	10	10	10	10	10	10	10	10
	psi	145	145	145	145	145	145	145	145	145	145
Max. speed continuous	rpm	1200	1500	1200	1500	1200	1500	1200	1500	1500	1700
Min. speed continuous	rpm	700	700	700	700	700	700	700	700	700	700
Power requirement at max. speed and 80 bar (1160 psi)	kW	55	59	64	65	70	71	81	83	101	105
	hp	73.6	78.9	86.3	86.9	93.8	95.1	108.3	111.6	135.3	141.4
Torque at 80 bar	Nm	431	371	510	410	556	451	639	530	643	593 ⁴⁾
	lbf-ft	318	273.6	376	302	410	332.6	471.3	391	474.3	437.1 ⁴⁾
Weight	kg	105	105	105	105	105	105	105	105	105	105
	lb	231.5	231.5	231.5	231.5	231.5	231.5	231.5	231.5	231.5	231.5
Integrated flushing valve		Yes	Yes	Yes	Yes	Yes	Yes	Yes	Yes	Yes	Yes

¹⁾ Typical average flow at 60 bar (870 psi)

²⁾ For lower pressure, please contact Danfoss High Pressure Pumps

³⁾ For higher pressure, please contact Danfoss High Pressure Pumps

⁴⁾ Torque at 70 bar

The pump is designed according to EN809.

4. Variants

- Available as ATEX certified. Category 2, zone 1 and category 3, zone 2
- Available with pressure containing parts in Super Duplex (according to NORSOK)
- Available with material certificates on metallic wetted parts
- Available with API 674 design verification

For more details on the variants, please contact the Danfoss High Pressure Pumps.

5. Flow at different rpm

When using the diagrams shown below, it is easy to select the pump which fits the application best if the flow required and the rotation speed (rpm) of the pump are known.

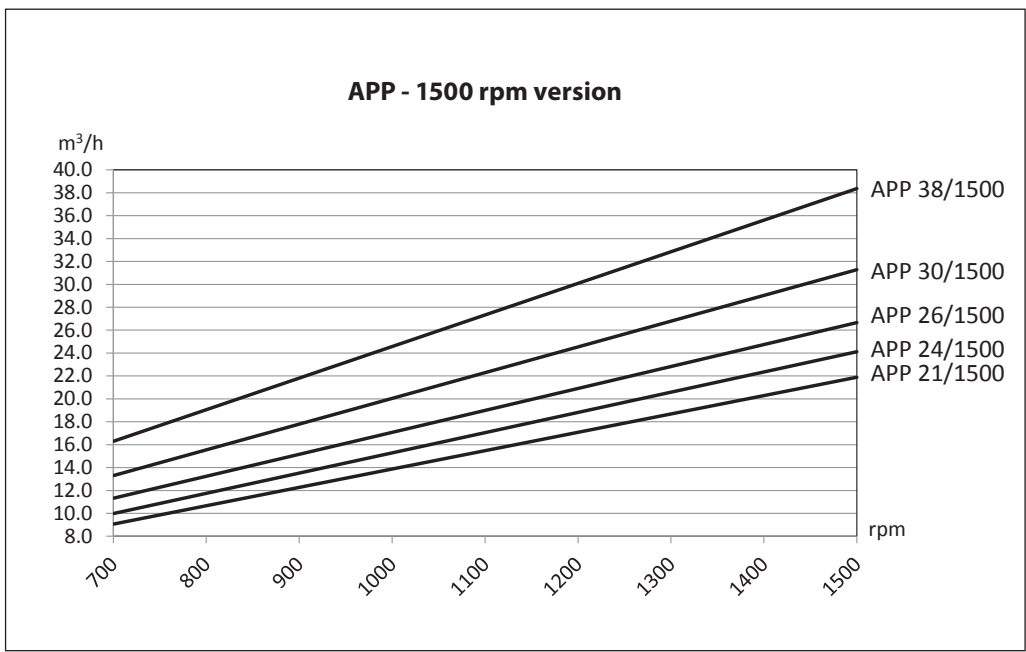
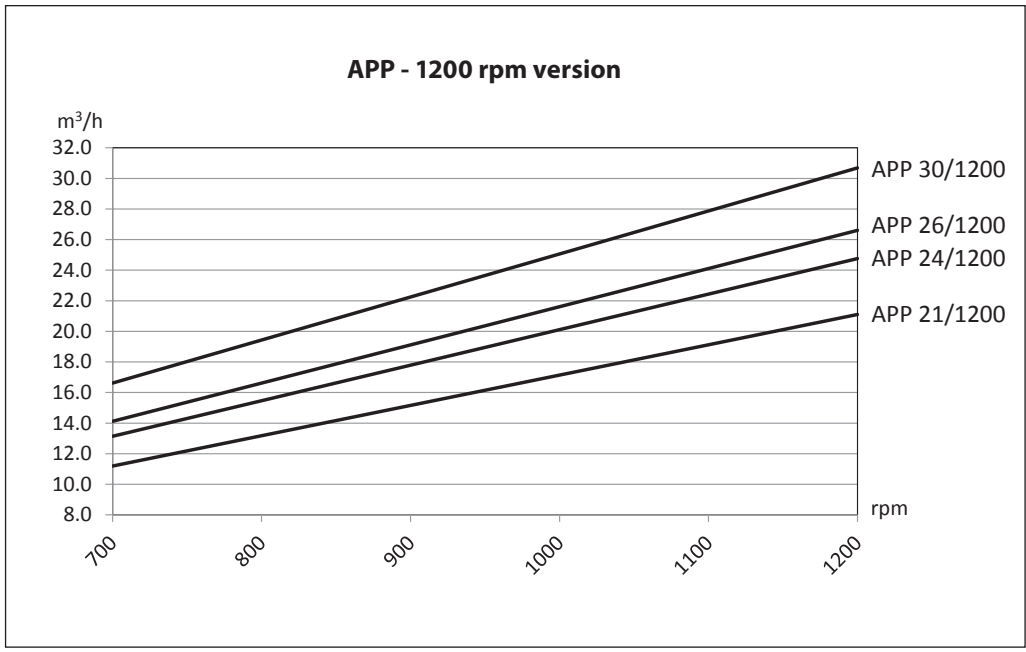

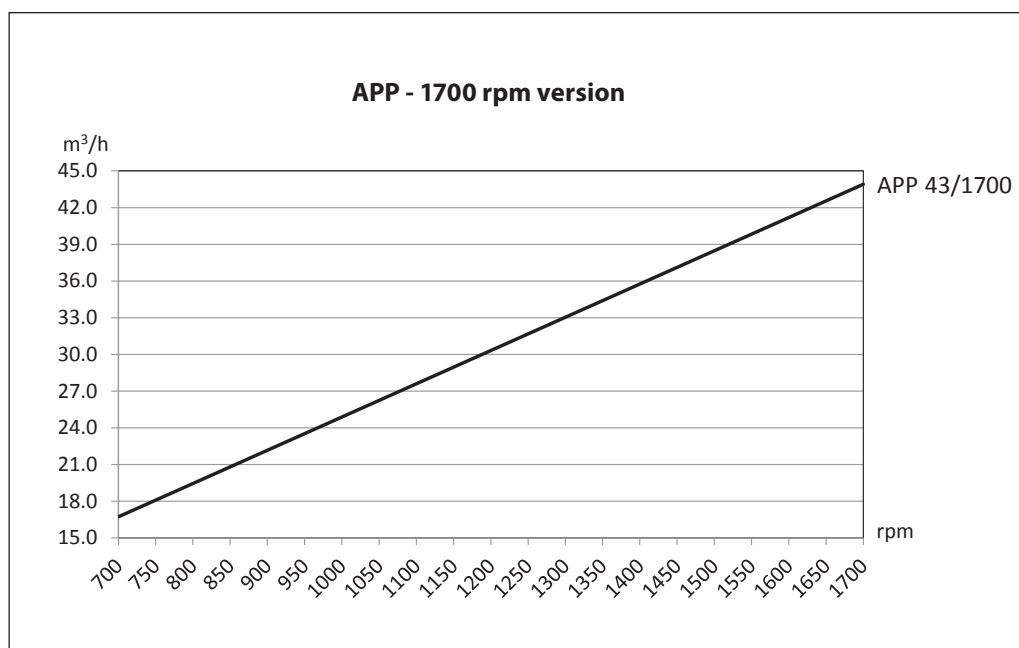

Furthermore, these diagrams shows that the flow can be changed by changing the rotation speed of the pump. The flow/rpm ratio is constant, and the "required " flow can be obtained by changing the rotation speed to a corresponding value. Thus, the required rpm can be determined as:

$$\text{Required rpm} = \frac{\text{Required flow} \times \text{Rated rpm}}{\text{Rated flow}}$$

6. Flushing valve

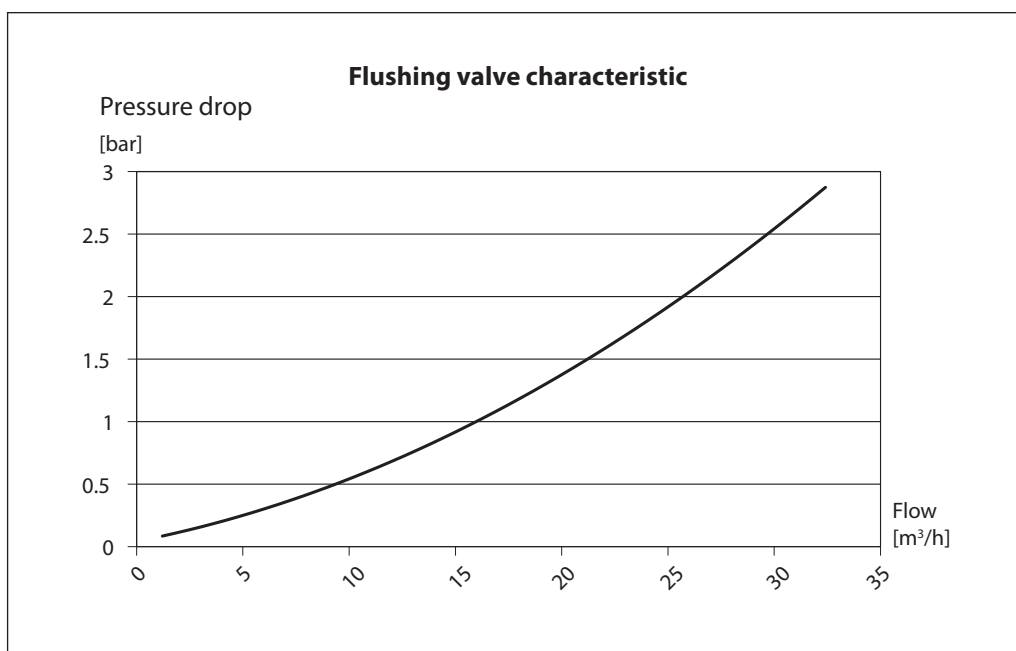

7. Power requirements

Pump model	Flow			Pressure			rpm	Calc. factor
	l/min	m³/h	gpm	60 bar	70 bar	80 bar		
				870 psi	1015 psi	1160 psi		
APP 21/1200	352	21.1	92.9	41 kW	48 kW	55 kW	1200	516
APP 21/1500	365	21.9	96.4	44 kW	52 kW	59 kW	1500	498
APP 24/1200	412	24.7	109	48 kW	56 kW	64 kW	1200	516
APP 24/1500	402	24.1	106.1	49 kW	57 kW	65 kW	1500	496
APP 26/1200	443	26.6	117.2	52 kW	61 kW	70 kW	1200	510
APP 26/1500	443	26.6	117.2	53 kW	62 kW	71 kW	1500	504
APP 30/1200	512	30.7	135.1	61 kW	71 kW	81 kW	1200	504
APP 30/1500	522	31.3	137.7	62 kW	73 kW	83 kW	1500	504
APP 38/1500	640	38.4	168.9	76 kW	88 kW	101 kW	1500	505
APP 43 / 1700	743	44.6	196.4	91 kW	106 kW		1700	503

The power requirements can be determined using one of the following guiding equations:

$$\text{Required power} = \frac{\text{l/min} \times \text{bar}}{\text{Calc. factor}} \text{ [kW]} \text{ or } \frac{16.7 \times \text{m}^3/\text{h} \times \text{bar}}{\text{Calc. factor}} \text{ [kW]} \text{ or } \frac{0.26 \times \text{gpm} \times \text{psi}}{\text{Calc. factor}} \text{ [kW]}$$

1 hp	=	0.75 kW
1 kW	=	1.34 hp
1 gpm	=	3.79 l/min
1 l/min	=	0.26 gpm
1 m³/h	=	4.40 gpm
1 gpm	=	0.23 m³/h

8. Temperature and corrosion

Fluid temperature: +2°C to +50°C (+35.6°F to 122°F) - dependent on the NaCl concentration
Ambient temperature: +2°C to +50°C (+35.6°F to 122°F)

8.1 Operation

The chart on the next page illustrates the corrosive resistance of different types of stainless steel related to NaCl concentration and temperature.

If the water pump is operated at high salinity, always flush the water pump with fresh water at operation stop in order to minimize the risk of crevice corrosion.

All critical parts of the APP water pump is made of Super Duplex.

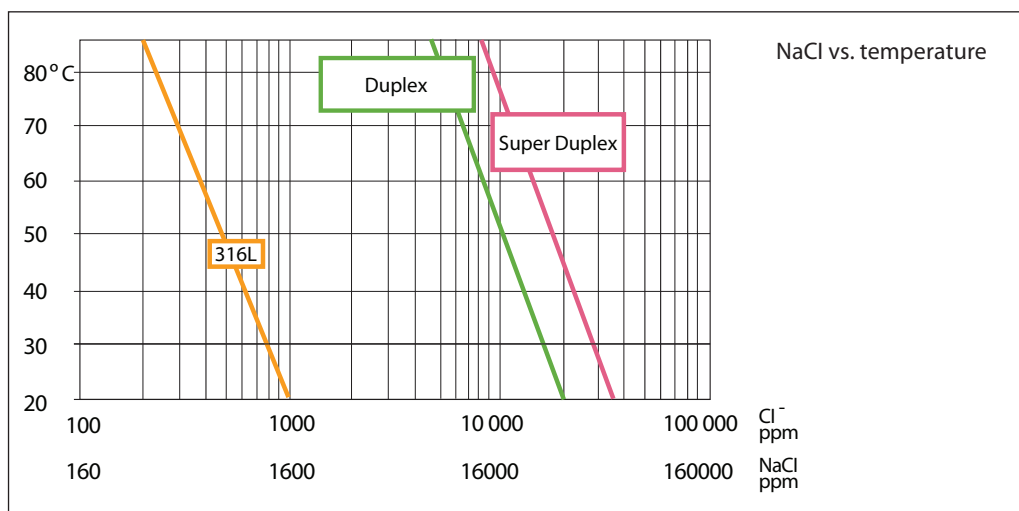

8.2 Storage

Storage temperature: -40°C to +70°C (+40°F to 158°F) – provided that the pump is drained of fluid and stored "plugged".
--

Frost protection is required at temperatures below 2°C. Danfoss recommends to use DOW-FROST from DOW Chemical Company or Chilsafe mono propylene glycol from Arco Chemical Company.

9. Noise level

The sound pressure levels, L PA, 1m db(A)* for APP 21-38 pumps are typically 85 dB(A) at 80 bar/1500 rpm. For APP 43 the sound pressure level, L PA, 1m db(A)* is 85.3 at 70 bar/1700 rpm. The sound pressure level for the APP 43 is including a rubber damper.

Generally, noise will be reduced if speed is reduced and vice versa. Use flexible hoses in order to minimize vibrations and noise.

Since the pump is typically mounted on a bell housing or frame, the noise level must be determined for the complete unit (system).

It is therefore very important that the motor/pump unit is mounted correctly on a frame with anti-vibration isolation to minimize vibrations and noise.

The noise level is influenced by:

- The speed of the pump, high rpm create more noise than low rpm
- Rigid mounting of the pump generates more noise than flexible mounting
- Pipe mounting direct to the pump increases the noise level compared to a flexible hose
- If using a VFD the motors can produce higher noise values depending on the operation point.

* Measurements according to EN ISO 3744 : 2010 dB(A)LPA, 1m) values is calculated according to EN ISO 20361 section 6.2.

10. Filtration

As water has very low viscosity, the APP pumps have been designed with very narrow clearance in order to control internal leakage rates and improve component performance. Therefore it is important that the inlet water is filtered properly to minimize the wear of the pump.

efficiency. This means that for each 100,000 particles reaching the filter, 50,000 particles pass through it compared to only 20 particles in a filter with an efficiency of 99.98%.

The main filter must have a filtration efficiency of 99.98% at 10 µm. We recommend to use precision depth filter cartridges rated 10µm abs. β10 ≥ 5000 (equivalent to a filtration efficiency of 99.98%). Bag filters and string wound filter cartridges typically have only 50% filtration

For more information on the importance of proper filtration, please consult our publication "Filtration" (code number 521B1009), which also will provide you with an explanation of filtration definitions and a guidance on how to select the right filter.

11. Dimensions

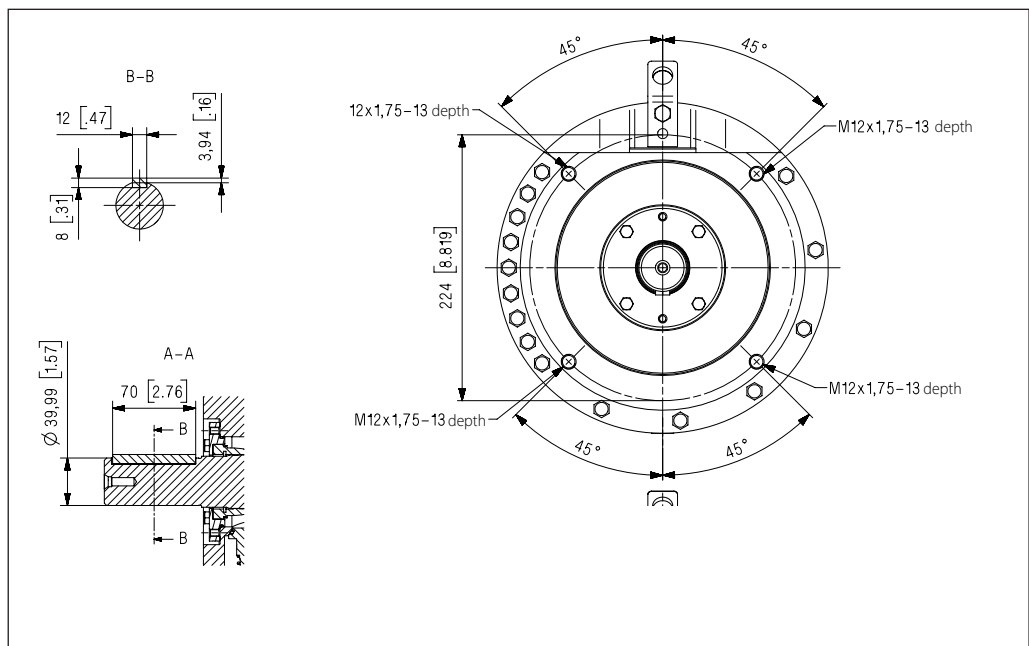
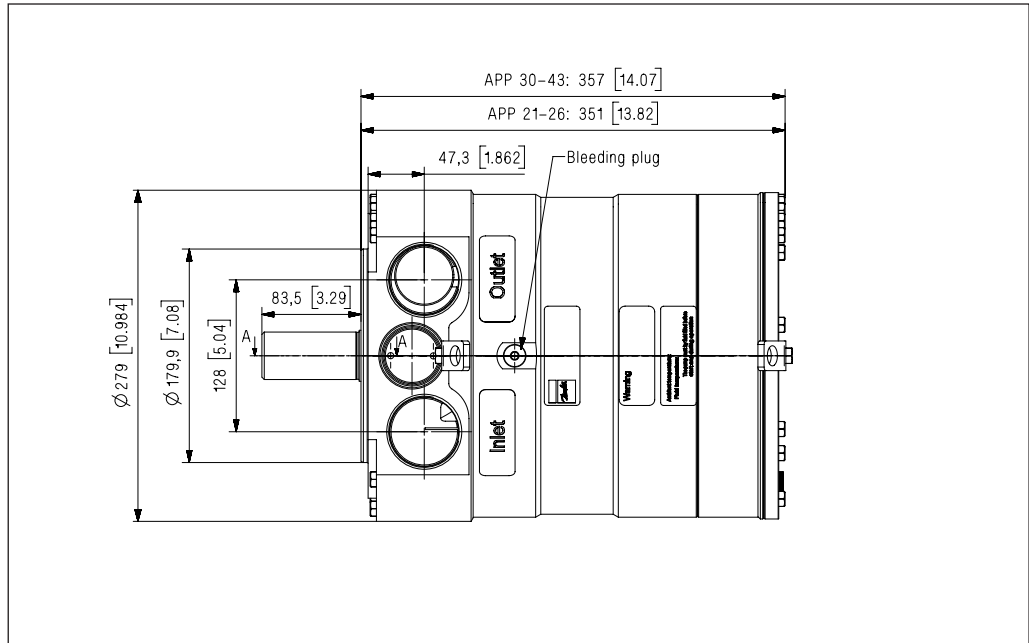

Description			APP 21 - APP 43
E	Parallel key, DIN 6885,	mm	12 × 8 × 70
		in	0.47 × 0.31 × 2.76
F	Bleeding	G ¼", Hexagon AF = 6 mm	
I	Inlet port	M60 x 1.5; depth 24 mm	
O	Outlet port	M60 x 1.5; depth 24 mm	
Mounting flange			ISO 3019-2 180B4TW

For more details on the accessories, please contact Danfoss High Pressure Pumps. Or check Data Sheets 521B1303/521B0909 available on website.

Accessories	Type	Code no.	
3" inlet hose kit	3" Victaulic	180Z0144	2.00 m [79"]
2" outlet hose kit APP 21-38	2½" Victaulic	180Z0263	1.78 m [70"]
		180Z0280	1.00 m [39.4"]
2½" outlet hose kit APP 43	2½" Victaulic	180Z0618	1.00 m [39.4"]
		180Z0619	1.78 m [70"]
2½" inlet connector APP 21-24	2½" Victaulic	180B3206	
3" inlet connector APP 21-43	3" Victaulic	180B3208	
Non-return valve (outlet) Duplex APP 21-38	2½" Victaulic (OD 73.1 mm)	180H0050	
Non-return valve (outlet) Super Duplex APP 21-38	2½" Victaulic (OD 73 mm)	180H0052	
Non-return valve (outlet) Super Duplex APP 21-43	2½" Victaulic (OD 73 mm)	180H0055	

12. Dimensions, complete unit

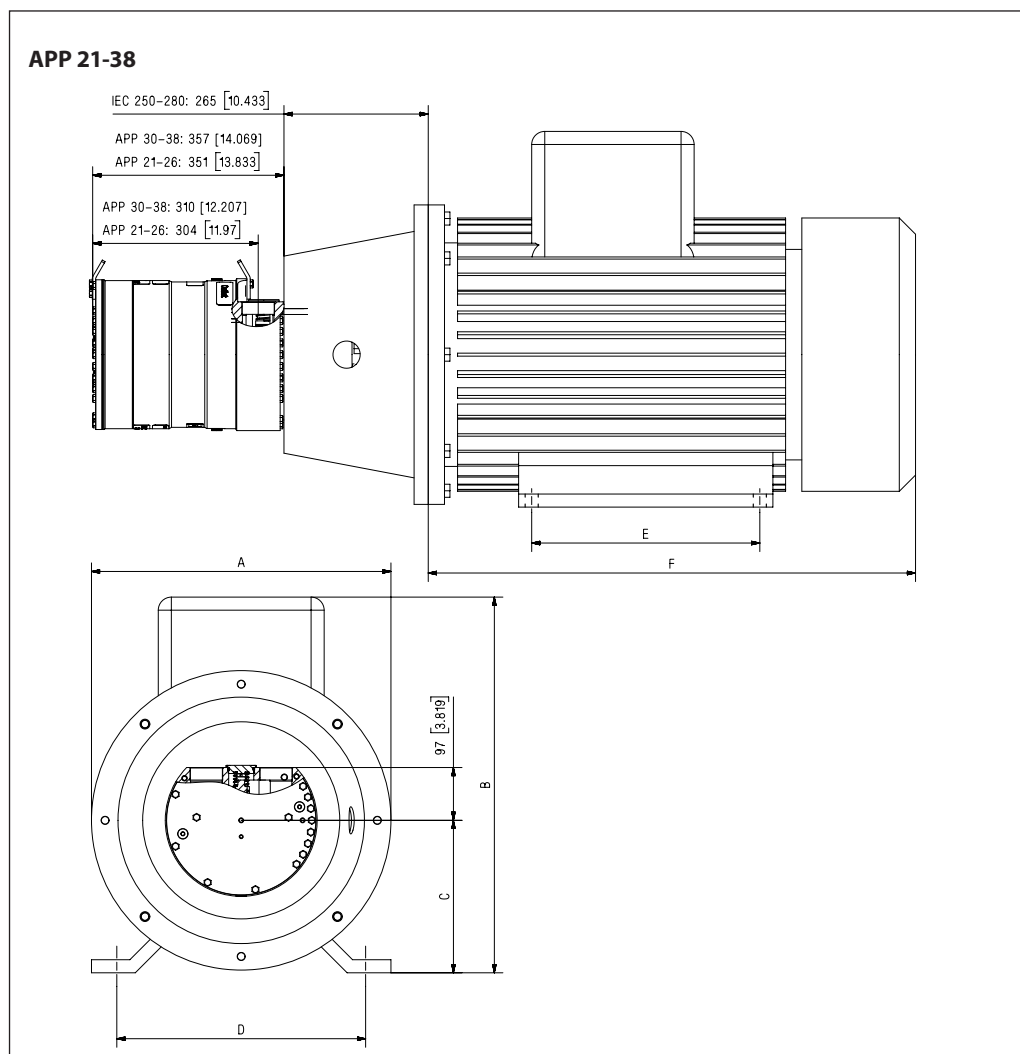

Pump	A (mm)	B (mm)	C (mm)	D (mm)	E (mm)	F (mm)	IEC Electric motor
APP 21-24	550	635	250	406	349	770	55 kW, IEC 250 M-4
APP 24-26	550	693	280	457	368	845	75 kW, IEC 280 S-4
APP 26-38	550	693	280	457	419	895	90 kW, IEC 280 M-4

Examples of different pump/motor sizes. Check required power.

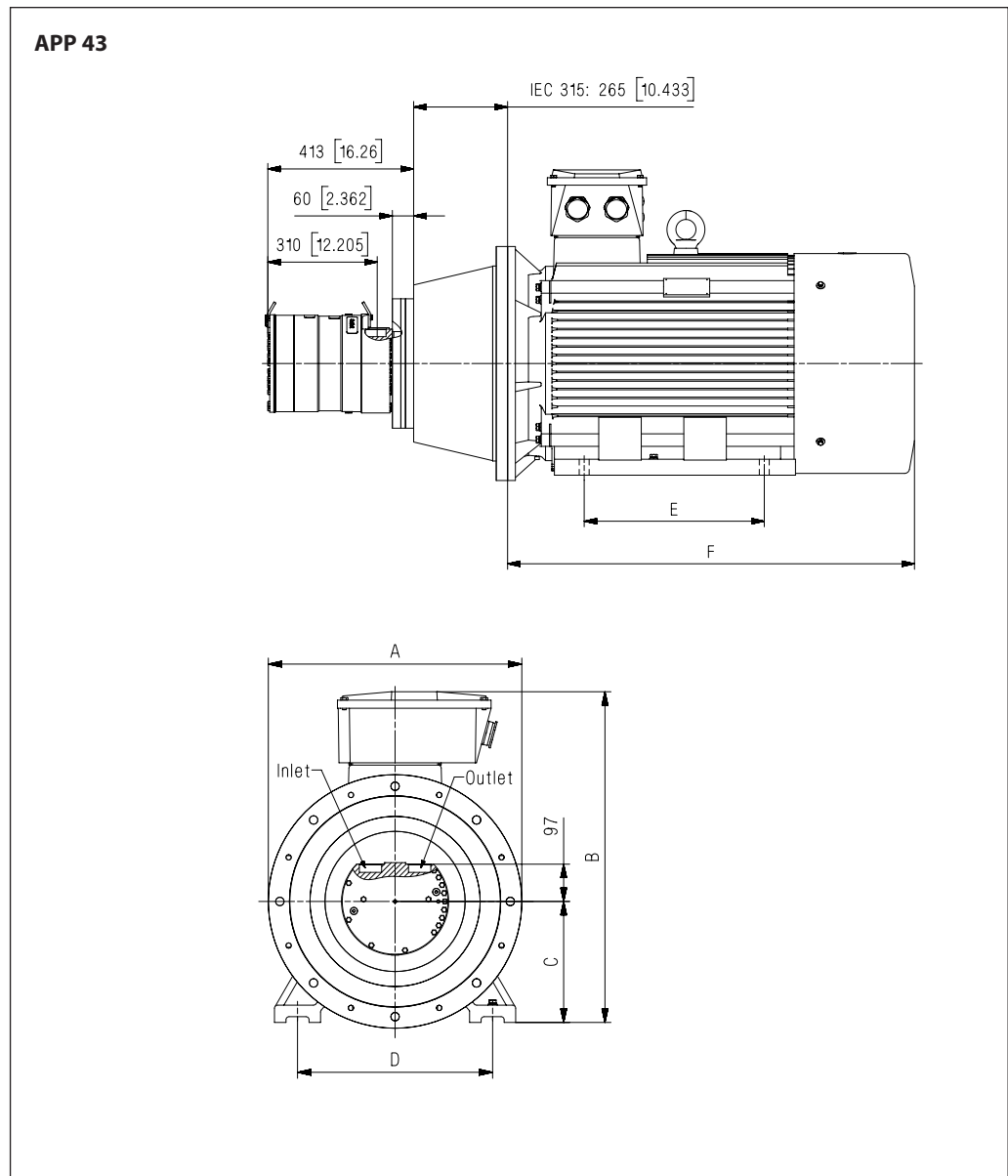

Pump	A (mm)	B (mm)	C (mm)	D (mm)	E (mm)	F (mm)	IEC Electric motor
APP 43	660	861	315	508	406	1038	110 kW, IEC 315 S-4

Above examples of different pump/motor sizes and drawing dimensions are only for IEC motors and couplings. Please make sure to check required motor power and dimensions when selecting size of pump and motor.

Due to the design and dimensions of an APP 43 pump, bell-housing and IEC motor, a dampening flange on the bell-housing is standard when an IEC 315 motor is selected.

If this dampening flange for some reason is deselected, an extension for the non-return valve may be needed in order to mount the pipe or hose with Victaulic clamps.

13. Installation

13.1 Mounting

The figure below illustrates how to mount the pump and connect it to the electric motor/ combustion engine.

If alternative mounting is required, please contact Danfoss High Pressure Pumps for further

information. To ensure easy mounting of the flexible coupling without using tools, the tolerances must be dimensioned accordingly.

Note: Any axial and radial loads on the pump shaft must be avoided.

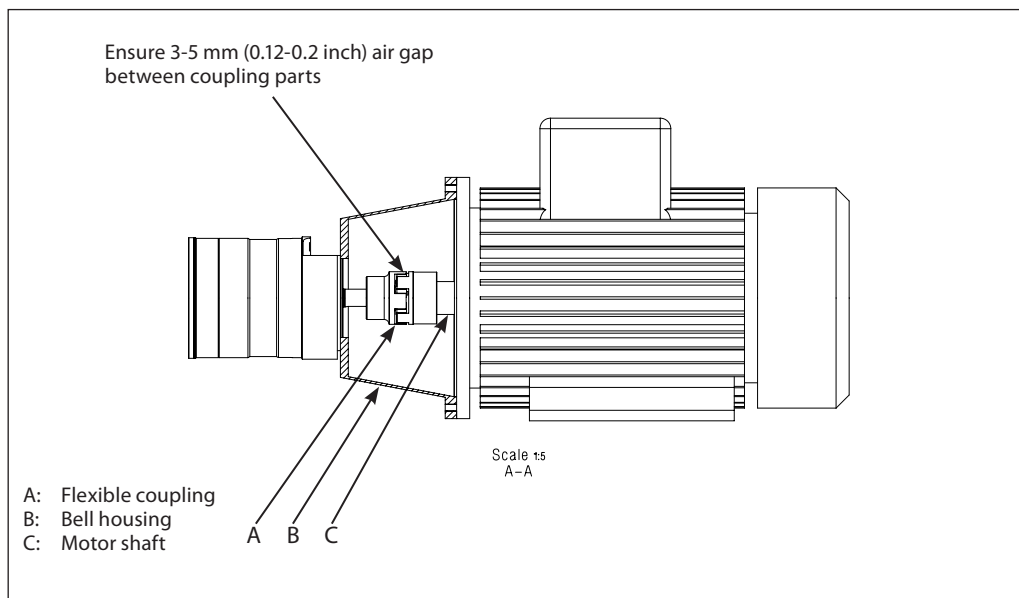

13.2 Open-ended system with direct water supply

In order to eliminate the risk of cavitation, a positive inlet pressure is always to be maintained. Please see technical data (section 3) for specific pressure values.

1. Place the filter (1) in the water supply line in front of the pump.
2. Place a monitoring pressure switch (2) - set at min. inlet pressure - between filter and pump inlet. The monitoring switch must stop the pump at pressures lower than min. inlet pressure. Please see technical data (section 3.) for specific pressure values
3. Install a low pressure safety valve or a pressure relief valve (3) in order to avoid system or pump damage in case the pump stops momentarily or spinning backwards.

Note: If a non return valve is mounted in the inlet line, a low pressure relief valve is also required between non return valve and pump as protection against high pressure peaks.

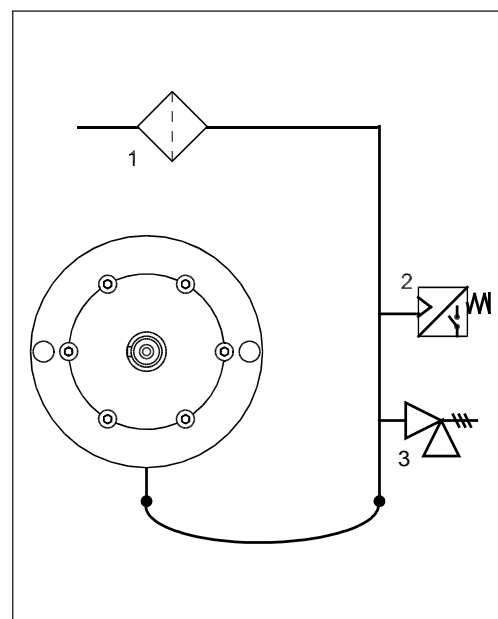

13.3 RO system with APP pump

1. Dimension the inlet line to obtain minimum pressure loss (large flow, minimum pipe length, minimum number of bends/connections, and fittings with small pressure losses).
2. Place an inlet filter (1) in front of the APP pump (2). Please consult section 10, "Filtration" for guidance on how to select the right filter. Thoroughly clean pipes and flush system prior to start-up.
3. Place a monitoring pressure switch (3) set at min. inlet pressure between filter and pump inlet. The monitoring switch must stop the pump at pressures lower than minimum pressure.
4. Use flexible hoses (4) to minimize vibrations and noise.
5. In order to eliminate the risk of damage and cavitation, a positive pressure at the inlet (5) is always to be maintained at min. inlet pressure and max. inlet pressure. Recommend to install safety valve or a

- pressure relief valve (9) in order to avoid high pressure peaks in case the pump stops momentarily or spinning backwards.
6. For easy system bleeding and flushing, a bypass non-return valve (6) is integrated in the APP pump.
7. A non-return valve (7) in outlet can be installed in order to avoid backspin of the pump. The volume of water in the membrane vessel works as an accumulator and will send flow backwards in case of the pump stops momentarily.
8. A safety valve or a pressure relief valve (8) can be installed in order to avoid system damage as the Danfoss APP pump creates pressure and flow immediately after start-up, regardless of any counterpressure.

Note: If a non return valve is mounted in the inlet line, a low pressure relief valve is also required between non return valve and pump as protection against high pressure peaks.

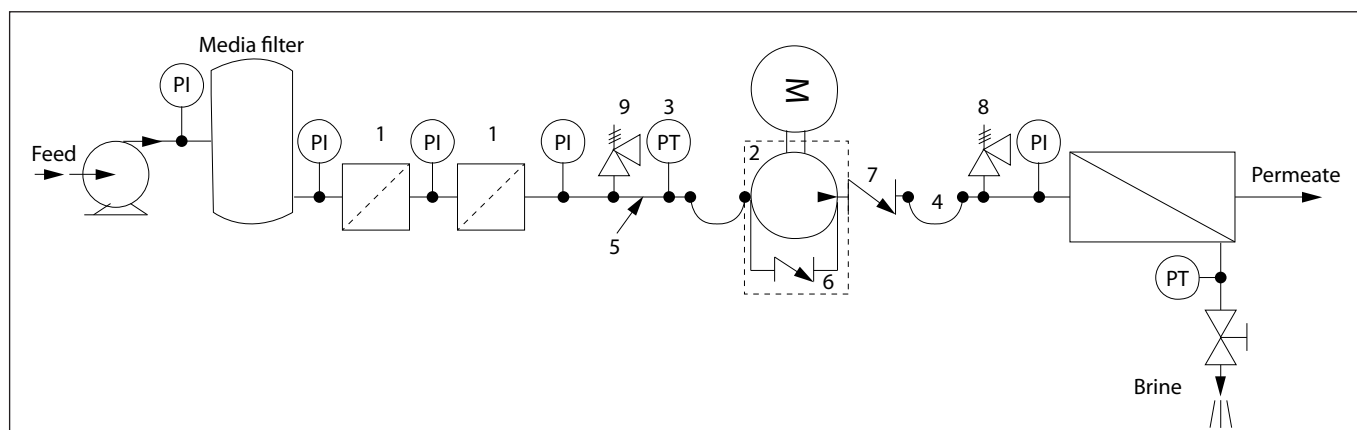

14. Service

14.1 Warranty

Danfoss APP pumps are designed for long operation, low maintenance and reduced lifecycle costs.

Provided that the pump has been running according to the Danfoss specifications, Danfoss guarantees 8,000 hours service-free operation, however, max. 18 months from date of production.

If Danfoss recommendations concerning system-design are not followed, it will strongly influence the life of the APP pumps.

14.2 Maintenance

After 8,000 hours of operation it is strongly recommended to inspect the pump and change any worn parts, e.g. pistons and shaft seal. This is done in order to prevent a potential breakdown of the pump.

If the parts are not replaced, more frequent inspection is recommended according to our guidelines.

Standstill

The APP pumps are made of Duplex/Super Duplex materials with excellent corrosion properties. It is, however, always recommended to flush the pump with freshwater when the system is shut down.

14.3 Repair

In case of irregular function of the APP, please contact Danfoss High Pressure Pumps.

Danfoss A/S
High Pressure Pumps
DK-6430 Nordborg
Denmark

Danfoss can accept no responsibility for possible errors in catalogues, brochures and other printed material. Danfoss reserves the right to alter its products without notice. This also applies to products already on order provided that such alterations can be made without subsequential changes being necessary in specifications already agreed. All trademarks in this material are property of the respective companies. Danfoss and the Danfoss logotype are trademarks of Danfoss A/S. All rights reserved.



Instruction

APP pump instruction

APP 21-43



Instruction APP pump instruction APP 21-43

Table of Contents	1.	Identification
Instruction APP 21-43 (180R9133)	2.	System design
	2.1	Open-ended systems with direct water supply
	2.2	Preferred RO system design and P&ID
	2.3	Reversible pumps
	2.4	General comments
	3.	Building up the pump unit
	3.1	Mounting
	3.2	Direction of rotation
	3.3	Orientation
	3.4	Protection from too high pressures
	3.5	Connections
	4.	Initial start-up
	5.	Operation
	5.1	Temperature
	5.2	Pressure
	5.3	Dry running
	5.4	Disconnection
	5.5	Storage
	6.	Service
	6.1	Warranty
	6.2	Maintenance
	6.3	Repair
	7.	EC Declaration of Conformity

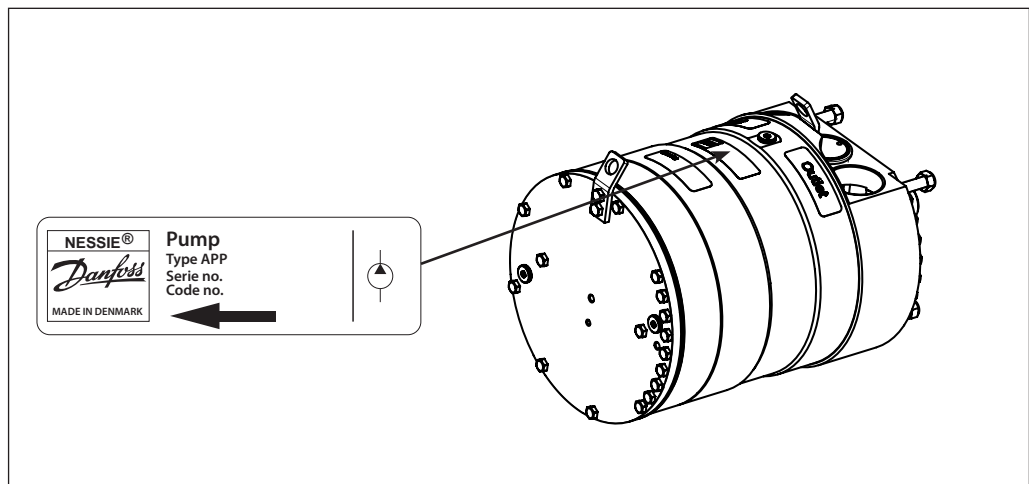
1. Identification

2. System design

The design of the system must ensure that self-emptying of the pump during standstill is avoided.

The inlet pressure of the pump must never exceed the outlet pressure. This may typically occur in boosted or open-ended systems with direct water supply.

2.1 Open-ended systems with direct water supply

The pump is supplied with water directly from a feed pump.

The inlet pressure for APP 21-38 must be at least 2 bar (29 psi) and **3 bar (43.5 psi) for the APP 43**. It must not exceed 5 bar (72.5 psi) continuous.

To protect the pump from being damaged by peaks of high-pressure in case the pump stops momentarily, it is required to mount a low-pressure relief valve on the inlet line.

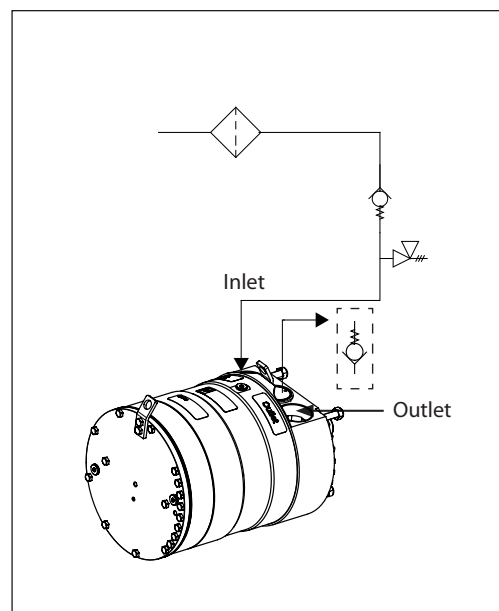

2.2 Preferred RO system design and P&ID

1. Dimension the inlet line to obtain minimum pressure loss (large flow, minimum pipe length, minimum number of bends/connections, and fittings with small pressure losses).
2. Place an inlet filter (1) in front of the APP pump (2). Please consult Danfoss filter datasheet for guidance on how to select the right filter. Thoroughly clean pipes and flush system prior to start-up.
3. Place a monitoring pressure switch (3) set at min. inlet pressure between filter and pump inlet. The monitoring switch must stop the pump at pressures lower than minimum pressure.
4. Use flexible hoses (4) to minimize vibrations and noise.
5. In order to eliminate the risk of damage and cavitation, a positive pressure at the inlet (5) is always to be maintained at min. inlet pressure and max. inlet pressure.

- It is recommend to install safety valve or a pressure relief valve (9) in order to avoid high-pressure peaks in case the pump stops momentarily or is spinning backwards.
6. For easy system bleeding and flushing, a bypass non-return valve (6) is integrated in the APP pump.
 7. A non-return valve (7) in outlet can be installed in order to avoid backspin of the pump. The volume of water in the membrane vessel works as an accumulator and will send flow backwards in case of the pump stops momentarily.
 8. A safety valve or a pressure relief valve (8) can be installed in order to avoid system damage as the Danfoss APP pump creates pressure and flow immediately after start-up, regardless of any counter pressure.

Note: If a non return valve is mounted in the inlet line, a low pressure relief valve is also required between non return valve and pump as protection against high-pressure peaks.

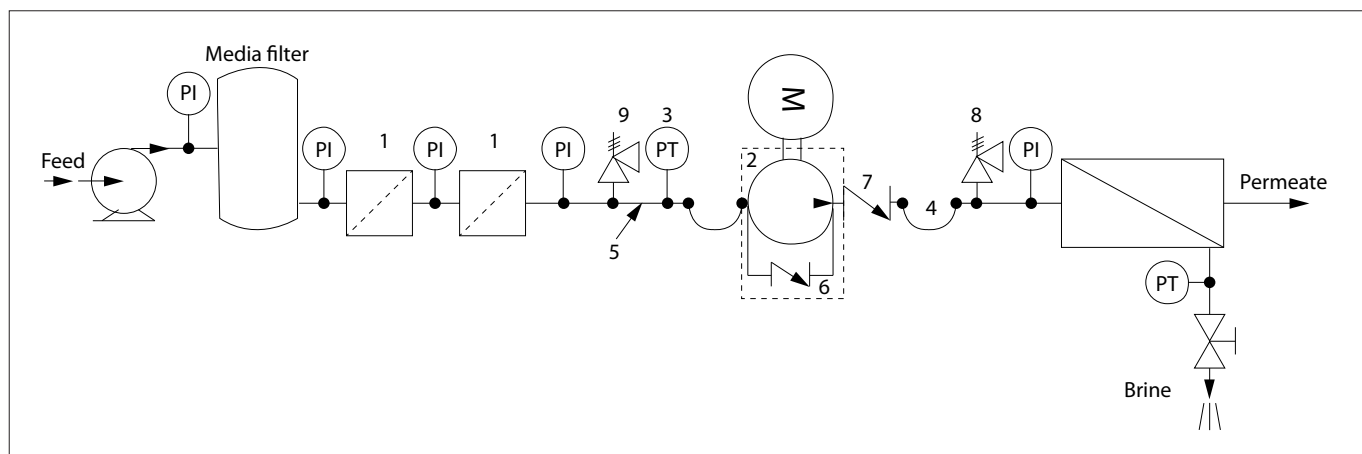

2.3 Reversible pumps

If exposed to high-pressure in the outlet while the electric motor is not energized, the pumps will start spinning backwards. This will not harm the pumps as long as the pressure in the inlet does not exceed the max. pressure peak of 10 bar (145 psi).

If a non-return valve is mounted in the inlet line, a low-pressure relief valve is also required as protection against high-pressure pulses and high-pressure in general.

Alternatively a high-pressure check valve can be mounted in the pump discharge line to prevent the pump from reversing.

The dotted setup ensures that the inlet pressure does not exceed 10 bar (145 psi), when a non-return valve is mounted in the inlet.

In order to avoid the risk of cavitation, the inlet pressure for APP 21-38 must be min. 2 bar (29 psi). And 3 bar (43.5 psi) for APP 43. The inlet line connection must be properly tightened, as possible entrance of air will cause cavitation.

As water has very low viscosity, the APP pumps have been designed with very narrow clearance in order to control internal leakage rates and improve component performance. Therefore it is important that the inlet water is filtered properly to minimize the wear of the pump.

The main filter must have a filtration efficiency of 99.98% at 10 µm. We recommend to use precision depth filter cartridges rated 10 µm abs. β10 ≥ 5000 (equivalent to a filtration efficiency of 99.98%). Bag filters and string wound filter cartridges typically have only 50% filtration efficiency. This means that for each 100,000 particles reaching the filter, 50,000 particles pass through it compared to only 20 particles in a filter with an efficiency of 99.98%.

For more information on the importance of proper filtration, please consult our publication "Filtration" (code number 521B1009), which also will provide you with an explanation of filtration definitions and a guidance on how to select the right filter.

2.4 General comments

Filtration

A good filtration is vital to ensure a long and trouble free life of the pump.

Monitoring

It is recommended to continuously monitor the following conditions:

- Filter clogging
- Pressure (inlet- and outlet side of the pump)

3. Building up the pump unit

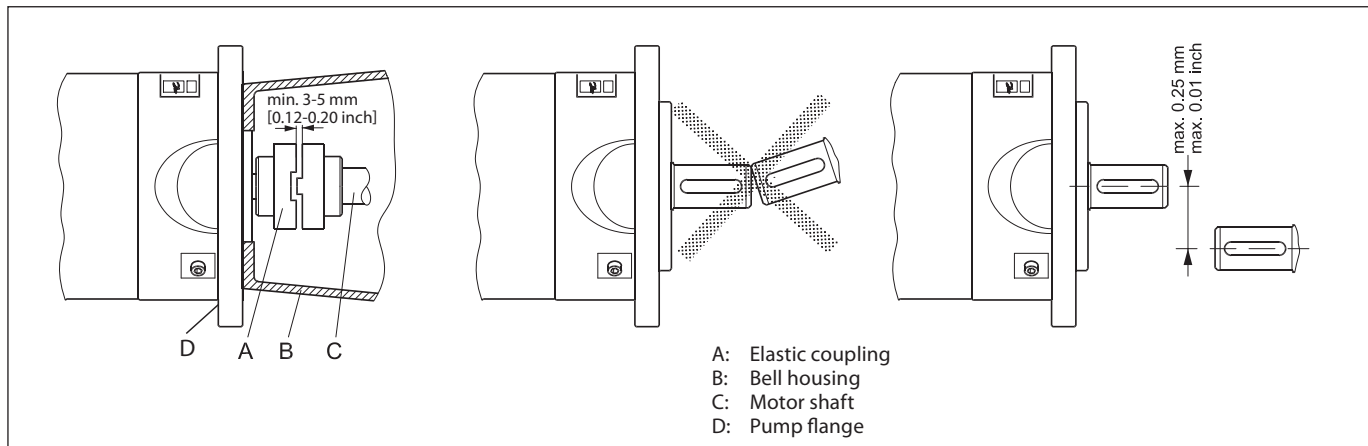

3.1 Mounting

1. Mount the coupling flush or maximum 1 mm offset from the pump shaft end. Ensure an air gap between coupling and pump flange of min. 4 mm (0.16 inch).
2. Mount the bell housing on pump. Secure nuts with the right torque.
3. Measure the longest distance "A" from top of bell housing to the button of coupling claw.

4. Mount the coupling on motor shaft. Ensure the coupling and motor flange are not in contact with each other.
5. Measure from motor flange to the top of the coupling. That measurement "B" shall be 3-5 mm (0.12 - 0.2 inch) shorter than the measurement "A".

("A" and "B" can be found on the next page).

6. Adjust respectively, verify the measurement, and secure both couplings with the right torques on the locking screws (see coupling operation & mounting instruction).
7. Mount the elastic gear ring and mount the bell housing/pump on the motor. After mounting it must be possible to move the elastic gear ring 3-5 mm (0.12 - 0.2 inch) axial "C". The check can be done through the inspection hole of bell housing. Secure flange bolts with the right torque.

If alternative mounting is desired, please contact Danfoss High Pressure Pumps sales organization.

Choose proper tolerances to ensure an easy mounting of the elastic coupling without use of tools.

Please take care to observe the recommended length tolerances of the chosen coupling, as an axial force on the pump will damage the pump.

("C" can be found on the drawing below).

1: Bolts and nuts: torque 75 Nm ±5 Nm
 2: Bolts and nuts: torque 40 Nm ±4 Nm
 3: Torque see table below

Thread size	M4	M5	M6	M8	M10	M12	M16
Torque (Nm)	1.5	2	4.8	10	17	40	80

3.2 Direction of rotation

Is indicated by an arrow on the pump label.

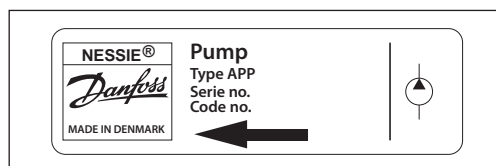

3.3 Orientation

The pump can be mounted/orientated in any horizontal direction with the inlet and the outlet pointing upwards, downwards or to either side.

3.4 Protection from too high pressures

The pump should be protected against too high pressure by means of a safety valve or a pressure relief valve.

The valve should be placed as close to the pump as possible.

The opening characteristics of the valve must not result in peak pressures higher than 100 bar (1,450 psi).

Both the inlet and outlet lines must be flexible soft hoses.

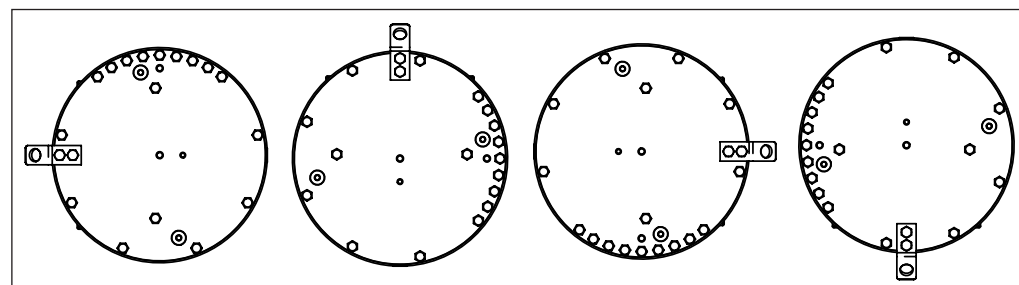

The valve outlet must not be connected directly to the pump suction line. It must be connected directly to the drain.

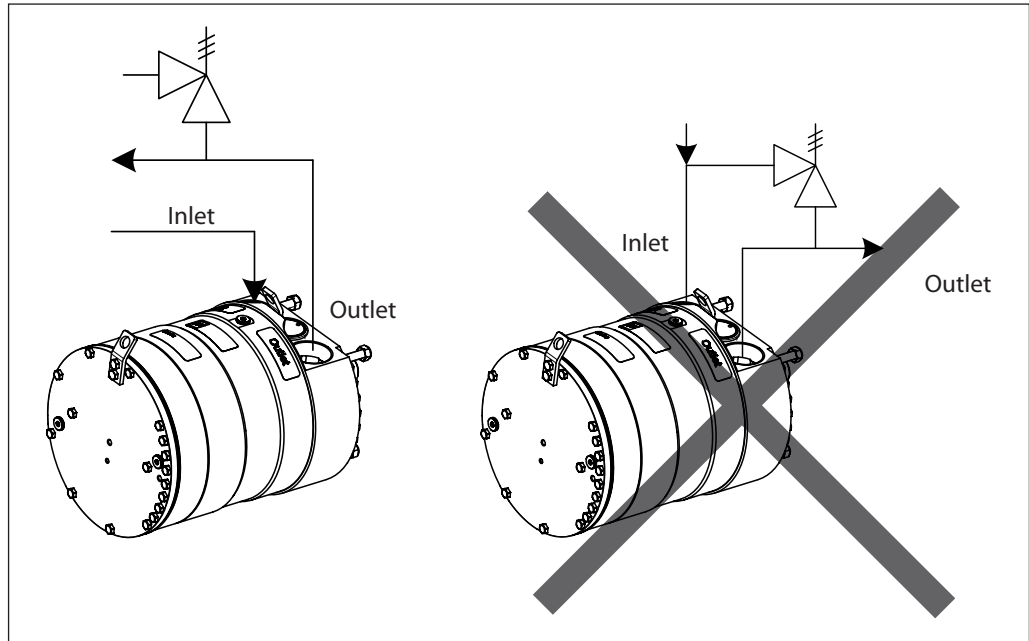

3.5 Connections

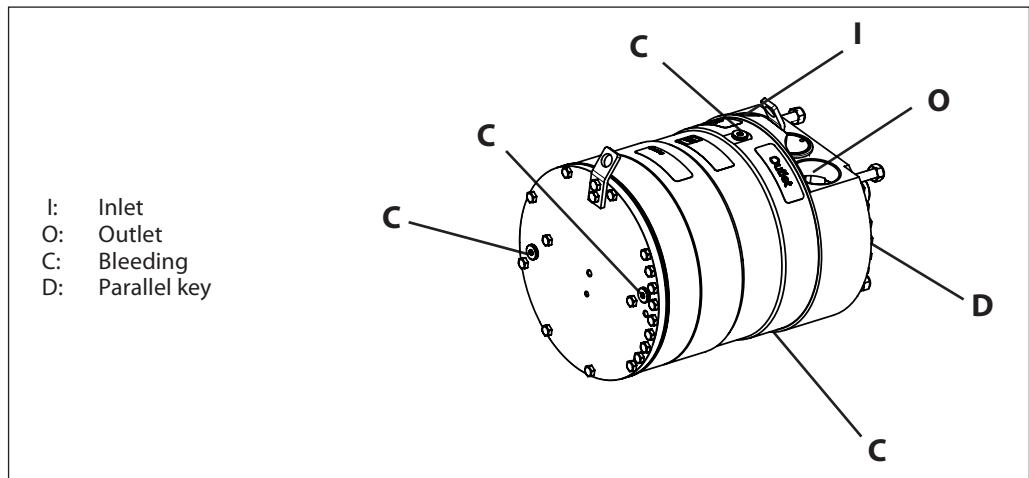

Description			APP 21 - APP 43
E	Parallel key, DIN 6885,	mm	12 × 8 × 70
		in	0.47 × 0.31 × 2.76
F	Bleeding	G ¼", Hexagon AF = 6 mm	
I	Inlet port	M60 x 1.5; depth 24 mm	
O	Outlet port	M60 x 1.5; depth 24 mm	
Mounting flange			ISO 3019-2 180B4TW

Accessories	Type	Code no.	
3" inlet hose kit	3" Victaulic	180Z0144	2.00 m [79"]
2" outlet hose kit APP 21-38	2½" Victaulic	180Z0263	1.78 m [70"]
		180Z0280	1.00 m [39.4"]
2½" outlet hose kit APP 43	2½" Victaulic	180Z0618	1.00 m [39.4"]
		180Z0619	1.78 m [70"]
2½" inlet connector APP 21-24	2½" Victaulic	180B3206	
3" inlet connector APP 21-43	3" Victaulic	180B3208	
Non-return valve (outlet) Duplex APP 21-38	2½" Victaulic (OD 73.1 mm)	180H0050	
Non-return valve (outlet) Super Duplex APP 21-38	2½" Victaulic (OD 73 mm)	180H0052	
Non-return valve (outlet) Super Duplex APP 21-43	2½" Victaulic (OD 73 mm)	180H0055	

For more details on the accessories, please contact Danfoss High Pressure Pumps. Possible extension see next page.

4. Initial start-up

1. Flush inlet line before connecting the pump, to remove possible impurities from pipes, hoses etc.
2. Connect pump inlet to inlet line and flush the pump for 5 min. by means of the internal flushing valve, to remove possible impurities from pipes, hoses etc.
3. Loosen top bleeding plug "C" (see item 3.3) using an allen key (only plugs with internal hexagan sockets). Retighten the plug, when water appears from the bleeding plug.
4. Make sure that the direction of rotation of the electric motor corresponds to the direction of rotation of the pump (see label on pump).
5. Now the pump is ready for start-up.

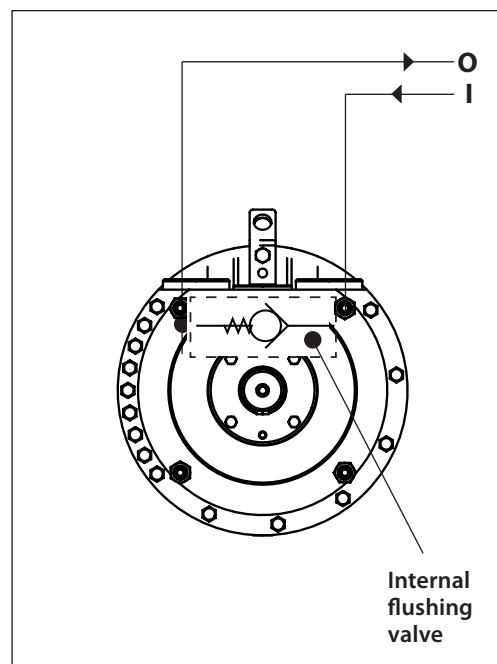

WARNING

Make sure that the direction of rotation of the electric motor corresponds to the direction of rotation of the pump (see label on pump). Otherwise the pump will be damaged if a check valve is placed between pump and feed pump.

5. Operation

5.1 Temperature

Fluid temperature:
Min. +2°C to max. +50°C
(Min. +35.6°F to max. +122°F)

Ambient temperature:
Min. +2°C to max. +50°C
(Min. +35.6°F to max. +122°F)

The chart below illustrates the corrosive resistance of different types of stainless steel related to NaCl concentration and temperature.

The APP water pump is made of Duplex and Super Duplex.

In case of lower operating temperatures, please contact Danfoss High Pressure Pumps sales organization.

If the water pump is operated above the Super Duplex line, always flush water pump with fresh water at operation stop in order to minimize the risk of crevice corrosion.

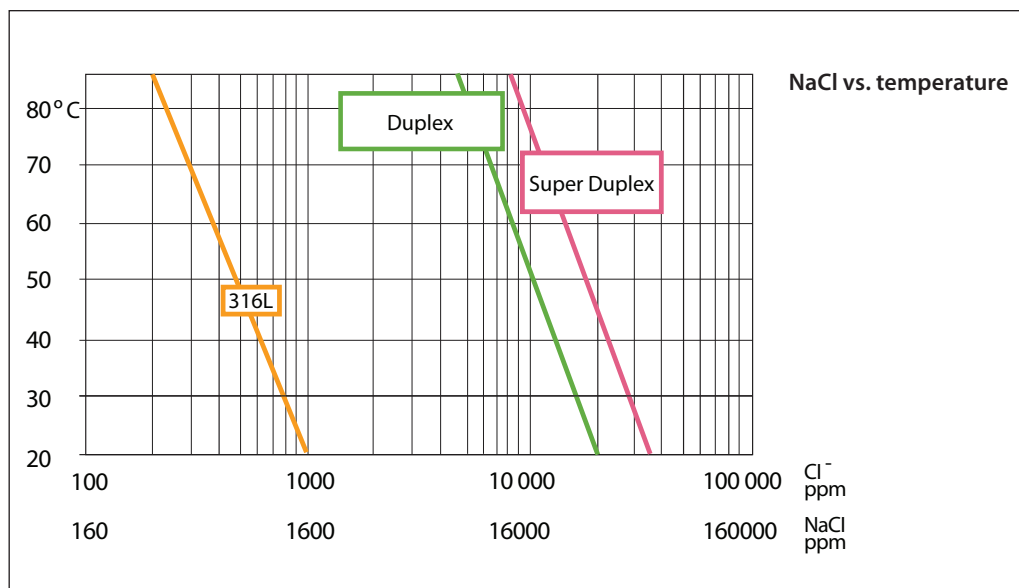

5.2 Pressure

The inlet pressure for APP 21-43 must be min. 2 bar (30 psi) and max. 5 bar (72.5 psi). At lower pressures the pump will cavitate, resulting in damage of the pump.

Max. inlet pressure peak (e.g. in case the pump stops momentarily) up to 10 bar (145 psi) are acceptable.

Max. pressure on the pump's outlet line should be limited at 80 bar (1,160 psi) continuously, 70 bar for APP 43

Note: The pump unit should include a pressure gauge on the high-pressure side.

5.3 Dry running

When running, the pump must always be connected to the water supply in order to avoid damage if it should run dry.

5.4 Disconnection

If the inlet line is disconnected from the water supply, the pump will be emptied of water through the disconnected inlet line.

When starting up again, follow the bleeding procedure described under section 4: Initial start up.

5.5 Storage

Storage temperature:
Min. -40°C to max. +70°C
(Min. -40°F to max. +158°F)

When preparing the pump for long-term storage or for temperatures below the freezing point, flush the pump with an anti-freeze medium type monopropylene glycol to prevent internal corrosion or frost in the pump.

For further information on anti-freeze media, please contact Danfoss High Pressure Pumps sales organization.

Recommended procedure:

1. Disconnect the water supply to the pump.
2. Through the lower bleeding plug, empty the pump housing of water and close it again.
3. Connect the pump to a tank containing anti-freeze additive. Connect a hose to the inlet port of the pump and via another hose return the flow from the outlet port to the tank with antifreeze additives.
4. Quickly start and stop the pump. **Make sure that the pump does not run dry.** The pump is now protected against internal corrosion and frost.

6. Service

6.1 Warranty

Danfoss APP pumps are designed for long operation, low maintenance and reduced lifecycle costs.

Provided that the pump has been running according to the Danfoss specifications, Danfoss guarantees 8,000 hours service-free operation, however, max 18 months from date of production.

If Danfoss recommendations concerning system-design are not followed, it will strongly influence the life of the APP pumps.

6.2 Maintenance

After 8,000 hours of operation, **it is strongly recommended** to inspect the pump and change any worn parts, e.g. pistons and shaft seal.

This is done in order to prevent a potential breakdown of the pump. If the parts are not replaced, more frequent inspection is recommended according to our guidelines.

Standstill:

The APP pumps are made of Duplex/Super Duplex materials with excellent corrosion properties. **It is however, always recommended to flush the pump with freshwater when the system is shut down.**

6.3 Repair

In case of irregular function of the APP, please contact Danfoss High Pressure Pumps sales organisation.

Danfoss A/S
High Pressure Pumps
DK-6430 Nordborg
Denmark

Danfoss can accept no responsibility for possible errors in catalogues, brochures and other printed material. Danfoss reserves the right to alter its products without notice. This also applies to products already on order provided that such alterations can be made without subsequential changes being necessary in specifications already agreed. All trademarks in this material are property of the respective companies. Danfoss and the Danfoss logotype are trademarks of Danfoss A/S. All rights reserved.



Electric Motors

Motor Manual

hoyermotors.com

Manual

HOYER ▶
MOTORS

1. General

This manual concerns the following types of standard induction motors from Hoyer:

HMA2, HMC2, HMD, HMT, MS, Y2E1, Y2E2, YDT

These motors are manufactured in accordance with IEC/EN 60034-4 and IEC/EN 60072.

Motors are rated for the ambient temperature range -20°C to $+40^{\circ}\text{C}$ and site altitudes ≤ 1000 m above sea level.

Low-voltage motors are components for installation in machinery. They are CE marked according to the Low Voltage Directive 2006/95/EC

2. Transport and storage

Check the motor for external damage immediately upon receipt and, if found, inform the forwarding agent right away. Check all rating plate data, and compare it with the requirement of the motor.

Turn the shaft by hand to check free rotation, remove transport locking if used.

Transport locking must be used again for internal transport also. It is also important that transport locking is used when motors are transported mounted on equipment.

All motors should be stored indoors, in dry, vibration- and dust-free conditions.

Lifting eyebolts must be tightened before use. Damaged eyebolts must not be used, check before use. Lifting eyes at motor must not be used to lift the motor when it is attached to other equipment.

Before commissioning, measure the insulation impedance. If values are $\leq 10\text{M}$ at 25°C , the winding must be oven dried. The insulation resistance reference is halved for each 20°C rise in motor temperature.

It is recommended that shafts are rotated periodically by hand to prevent grease migration.

3. Installation

The motor must be fixed on a stable, clear and flat foundation. It must be sufficiently rigid to withstand possible short circuit forces.

It is important to ensure that the mounting conditions do not cause resonance with the rotational frequency and the doubled supply frequency.

Only mount or remove drive components (pulley, coupling, etc.) using suitable tools, never hit the drive components with a hammer as this will cause damage to the bearing.

The motor are balancing with half key, ensure that the drive components are also the same.

Correct alignment is essential to avoid bearing, vibration and shaft failure.

Use appropriate methods for alignment.

Re-check the alignment after the final tightening of the bolts or studs.

Check that drain holes and plugs face downwards. We recommend opening the drain hole for motors placed outdoors and not running 24 hours / day, so that the motor can breathe, thus ensuring a dry motor.

4. Electrical connection

Work is only permitted to be carried out by qualified specialists and must to be carried out in accordance with local regulations.

Before work commences, ensure that all power is switched off and cannot be switched on again. This also applies to the auxiliary power circuits, e.g. anti-condense heaters.

Check that supply voltage and frequency are the same as rated data.

Motors can be used with a supply deviation of $\pm 5\%$ voltage and $\pm 2\%$ frequency, according to IEC60034-1

Connection diagrams for main supply and accessory as PTC or heater are located inside the terminal box.

Connections must be made in such a way as to ensure that a permanently safe electrical connection is maintained, both for the main supply and the earth connection.

We recommend that crimped connections are made in accordance with IEC 60352-2.

Tightening torques for terminal board screws:

Thread	M5	M6	M8	M10	M12	M16	M20
T.(Nm)	2.5	3.5	7	12	18	35	55

Ensure that the terminal box is clean and dry.

Unused glands must be closed.

Check the terminal box gasket before it is remounted.

5. Maintenance

Inspect the motor at regular intervals, keep it clean and ensure free ventilation air flow, check the condition of shaft seals and replace if necessary. Both electrical and mechanical connections must be checked and tightened if necessary.

Bearing size and type are specified on the rating plate. Motor types HMA2 and HMC2 is as standard with lifetime greased bearing with motor size ≤ 225 .

Motor types MS and Y2E is as standard with lifetime greased bearing with motor size ≤ 160 .

Typical duty hours for lifetime lubricated bearings.

Frame size	Poles	Typical lifetime
56 – 160	2 – 8	40.000h
180	2	35.000h
200	2	27.000h
225	2	23.000h
180 – 225	4 – 8	40.000h

Motors with a re-greasing system must be lubricated with high quality lithium complex grease, NLGI grade 2 or 3, with a temperature range of between -40°C to $+150^{\circ}\text{C}$.

Motors are normal fitted with a data plate with greasing information; if it is missing use the following re-greasing intervals.

Frame size	Grease (g)	2 pole (h)	4 pole (h)	6 pole (h)	8 pole (h)
160	20	4200	7000	8500	8500
180	20	4200	7000	8500	8500
200	25	3100	6500	8500	8500
225	25	3100	6500	8500	8500
250	35	2000	6000	7000	7000
280	35	2000	6000	7000	7000
315	50	1500	5500	6500	6500
355	60	1000	4000	5000	6000
400	80	800	3000	4000	6000

Grease the motor while running, open the grease outlet plug and let the motor run 1-2 hours before the outlet grease plug is closed again.

Grease the motor for the first time during commissioning.

The following applies in general for both lifetime lubricated and re-lubricated bearings:

At 60Hz the time will be reduced by app. 20%.

Data for vertically mounted motors are half of the above values.

The table values are based on an ambient temperature of 25°C . The values must be halved for every 15K increase in bearing temperature.

Higher speed operations, e.g. frequency converter drive will require shorter greasing intervals. Typically, doubling the speed will reduce the values by 50%.

6. Special note for ATEX Zone 22 motors.

Notice for the use of electrical equipment in areas with combustible dust.

Designation of motor according to EC directive:

Ex II 3D T125 $^{\circ}\text{C}$, IP55.

The dust hazardous 3-phase asynchronous motors are in accordance with European standard EN 50281-1-1. Combustible dust areas will be found in agricultural areas and in industrial environments.

Only one electrical installation may be installed in one specified area (zone).

Only certificated cable glands for category 2D may be used. Unused glands must be closed.

Connections must be made in such a way as to ensure that a permanently safe electrical connection is maintained, both for the main supply and earth connection.

Installations must be in accordance with actual standards for installation in the Zone 22 area.

It is recommended that EN 50281-2 is followed according temperature and dust on the motor surface.

The use of motors with so much surface dust that the motor temperature increases is not permitted.

Regularly cleaning is recommended.

The radial shaft sealing ring is part of the ATEX certification. It is important that the ring is always intact.

The shaft sealing must be regularly checked, and if dry it must be lubricated. It is recommended that the seal is re-lubricated regularly.

Always use the original seal ring when replaced.

Replacing bearings also means replacing the seals.

All machines must be inspected regularly for mechanical damage.

The user is responsible for changing parts in accordance with the lifetime of parts, in particular:

bearings, grease and lubrication of shaft sealing.

Maintenance, repairs and replacement on zone 22 motors must only be carried out by qualified specialists.

Connection diagram
Anschlußdiagramm
Anslutningdiagramm
Forbindelsesdiagram
Aansluitdiagram
Connection
Conexión
Collegamento
Схема соединений
Schemat polaczeń

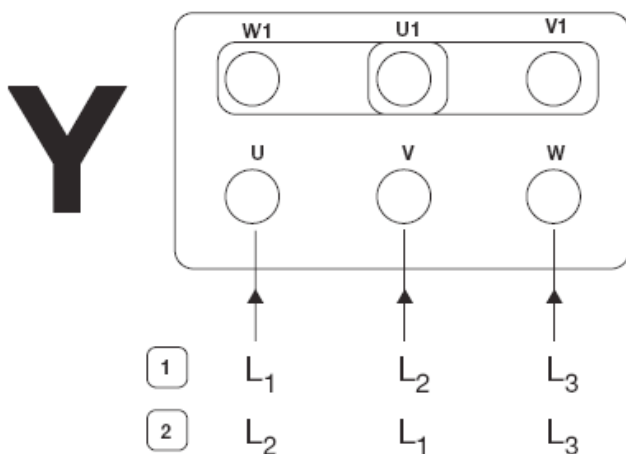
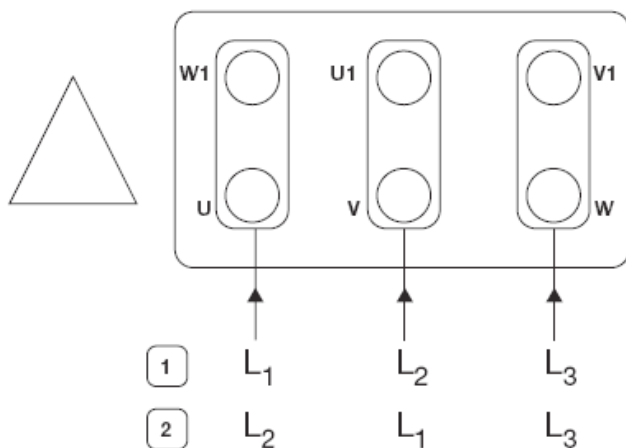

EC Declaration of Conformity

The Manufacturer: SVEND HØYER A/S
Over Hadstenvej 42
DK 8370 Hadsten
Denmark

Hereby declares that

The products: HOYER MOTORS, 3-phased induction motors

Aluminium motors	MS, A22 MS 56 - 180 HMA*, A22 HMA* 56 - 180
Cast iron motors	Y2E*, A22 Y2E* 80 - 400 HMC*, A22 HMC* 80 - 400

Are in conformity with the following:

Standards: EN 60 034-1 and EN 60 072
Directive: Low Voltage Directive 2006/95/EC
Year of CE marking: CE₀₂

Signed by



Lars Høyer

Managing Director

Date December 2010

Page 1/1.



Main office:

Svend Høyer A/S

Over Hadstenvej 42 · DK 8370 Hadsten

Tel. (+45) 86 98 21 11 · Fax (+45) 86 98 17 79

E-mail: svendhoyer@svendhoyer.dk · <http://www.svendhoyer.dk>

Sverige:

Svend Høyer AB

Malmövägen 18 · S-331 42 Värnamo

Tel. (+46) 37 04 77 13 · Fax (+46) 37 01 00 46

E-mail: svendhoyer@svendhoyer.se · <http://www.svendhoyer.se>

Norge:

Svend Høyer AS

Torvet 1 · N-3256 Larvik

Tel. (+47) 33 18 00 11 · Faks: (+47) 33 18 00 13

e-mail: svendhoyer@svendhoyer.no · <http://www.svendhoyer.no>

Deutschland:

Svend Høyer A/S

Over Hadstenvej 42 · DK 8370 Hadsten

Tlf. 0800 1890415 · Fax (+45) 87 61 21 19

E-mail: svendhoyer@svendhoyer.dk · <http://www.svendhoyer.de>

HOYER

Svend Hoyer A/S · Over Hadstenvej 42 · DK-8370 Hadsten
T +45 86 98 21 11 · F +45 86 98 17 79 · svendhoyer@svendhoyer.com · [svendhoyer.com](http://www.svendhoyer.com)

Instruction

Recommended service intervals for APP pumps



Instruction **Recommended service intervals for APP pumps**

Table of Contents	1.	General information
Recommended service intervals for APP pumps (180R9199)	2.	Design/features
	3.	Appendix 1

1. General information	This guideline provides information on the recommended service intervals. The recommendation is based upon good engineering practice and on experience gained from operation even under extreme conditions.	The recommendation is for guidance only.
-------------------------------	---	--

2. Design/features	Danfoss APP pumps are designed for long operation and low maintenance and life cycle costs. Danfoss guarantees 8,000 hours service free operation, however max. 18 months from date of production. After 8,000 operation hours it is recommended to inspect the pump and replace worn parts, if any.	If the Danfoss recommendations concerning system-design (see our data sheet) are not followed, the service life of the APP pumps might be affected. The recommended service intervals on the different parts in the APP pumps appear from the table below:
---------------------------	---	---

Pos.	Qty.	Description	Material	Service interval
1	1	Housing, main bearing	Duplex, PEEK	No need for service
11, 125, 211*	1	Mounting flange/ end flange	Wetted part: Duplex Dry part: AISI 316L	No wear part
121, 181*	1	Port flange	Duplex	No wear part
31	1	Swash plate	Super Duplex	40,000 hours
66	5/7/9	Piston	Super Duplex and PEEK	Recommended inspection on a yearly basis and evaluated acc. to app. 1
92	1	Valve plate	Super Duplex	24,000 hours
91	1	Port plate	Super Duplex, PEEK	24,000 hours
61	1	Cylinder barrel	Super Duplex	40,000 hours
65	1	Retainer plate	Super Duplex	24,000 hours
64	1	Retainer ball	Super Duplex	40,000 hours
71	1	Retainer guide	Super Duplex	40,000 hours
62	1/4	Spring	Duplex	40,000 hours
63	1	Spring guide	Duplex or PP	40,000 hours
142	1	Stop for shaft seal	PP	No wear part
124, 215*	1	Shaft seal	Hastelloy and NBR	It is good practice to change the seal after each disassembly of the pump
125	1	Cover/flange for shaft seal	Super Duplex	No wear part
93	5/7/9	Back-up ring	PTFE	24,000 hours
*		O-ring (overall)	NBR	24,000 hours
*		Screw (overall)	AISI 316	No wear part
*		Pin (overall)	AISI 316, Duplex or PEEK	No wear part
152	1	Valve cone (flushing valve)	Duplex or PEEK	40,000 hours
3, 129*	2	Bleeding screw	Duplex	No wear part
67	1	Key	AISI 316	40,000 hours

* depends on pump size

3. Appendix 1

Pistons:

The pistons are the heart of the pump regarding service.

If the pistons break down, the pump will suffer a breakdown.

In case of doubt - the pistons must be replaced.

The pictures below is ment as a guideline for evaluating the wear of the sliding surface.



Cavitation of the piston shoes.
New inspection is required in 3,000-4,000 hours.



Cavitation of the piston shoes.
All pistons must be replaced within the next 500-1,000 hours.



Cavitation of the piston shoes.
All pistons must be replaced within the next 100-200 hours.



Cavitation of the piston shoes.
All pistons must be replaced immediately.

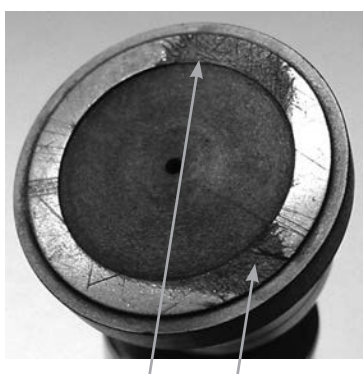

Abrasive wear of the piston shoes.
All pistons must be replaced immediately.

Danfoss A/S
High Pressure Pumps
DK-6430 Nordborg
Denmark

Danfoss can accept no responsibility for possible errors in catalogues, brochures and other printed material. Danfoss reserves the right to alter its products without notice. This also applies to products already on order provided that such alterations can be made without subsequential changes being necessary in specifications already agreed. All trademarks in this material are property of the respective companies. Danfoss and the Danfoss logotype are trademarks of Danfoss A/S. All rights reserved.

Parts list

APP Pumps APP 21-43



APP 21-43

Table of Contents
**Parts list APP 21-43
(521B0941)**

1.	General	
2.	Parts list APP 0.6 - 1.0 Compact	
3.	Exploded view APP 0.6 - 1.0 Compact	
4.	Parts list APP 0.6 - 1.0 and APM 0.8 - 1.2	
5.	Exploded view APP 0.6 - 1.0 and APM 0.8 - 1.2	
6.	Parts list APP 1.5 - 2.5 and APM 1.8 - 2.9	
7.	Exploded view APP 1.5 - 2.5 and APM 1.8 - 2.9	
8.	Parts list APP 3.0 - 3.5	
9.	Exploded view APP 3.0 - 3.5	
10.	Parts list APP 5.1 - 10.2	
11.	Exploded view APP 5.1 - 10.2	
12.	Parts list APP W 5.1 - 10.2	
13.	Exploded view APP W 5.1 - 10.2	
14.	Parts list APP 11 - 13	
15.	Exploded view APP 11 - 13	
16.	Parts list APP 16 - 19	
17.	Exploded view APP 16 - 19	
18.	Parts list APP 22	
19.	Exploded view APP 22	
20.	Parts list APP 21 - 26	
21.	Exploded view APP 21 - 26	
22.	Parts list APP 30 - 43	
23.	Exploded view APP 30/1200 and APP 43/1700	
24.	Tool sets	 Not included

1. General

This parts list provides an overview of the content of the various service sets for the

- APP 0.6-1.0 Compact
- APP 0.6-1.0
- APM 0.8-2.9
- APP 1.5-2.5
- APP 3.0-3.5
- APP 5.1-10.2
- APP W 5.1-10.2
- APP 11-13
- APP 16-22
- APP 21-43

as well as exploded views of the pumps.

Parts list

APP 0.6-43 / APM 0.8-2.9 / APP W 5.1-10.2

**20. Parts list
APP 21 - 26**

Note:
The parts listed are not sold separately,
only in various kits.

Exploded view, see next page.

Pos.	Qty.	Designation	Material	180B4171 – Seal set (APP 21-26)	180B4166 – Cylinder barrel (APP 21-26)	180B4165 – Valve plate set (APP 21-26)	180B4164 – Retainer set (APP 21-26)	180B4163 – Piston set (APP 21-24 / 1500 rpm)	180B4163 – Piston set (APP 21-26 / 1200 rpm)	180B4199 – Piston set (APP 26 / 1500 rpm)	180B4167 – Swash plate set (APP 21 / 1200 rpm - APP 26 / 1500 rpm)	180B4077 – Swash plate set (APP 21 / 1500 rpm)	180B4168 – Swash plate set (APP 24 / 1200 rpm)	180B4224 – Swash plate set (APP 24 / 1500 rpm)	180B4169 – Swash plate set (APP 26 / 1200 rpm)	180B4170 – Flushing valve set (APP 21-26)
1	1	Housing	Duplex / PEEK													
2	2	Pin (Ø6x10)	AISI 316	x												
3	2	Bleeding plug	Super Duplex	x												
4	4	O-ring (Ø11x2)	NBR	x												
5	17	Screw (M8x30)	AISI 316	x				x	x	x						
9	1	O-ring (Ø228x4)	NBR	x				x	x	x						
10	2	O-ring (Ø9.19x2.62)	NBR	x							x	x	x	x	x	
11	1	End flange	Duplex													
12	1	Lifting eye	AISI 316													
13	2	Screw (M8x16)	AISI 316	x												
31	1	Swash plate	Super Duplex								x	x	x	x	x	
34	2	Pin (Ø10.5x20)	Duplex	x							x	x	x	x	x	
61	1	Cylinder barrel	Super Duplex / PEEK		x											
62	4	Spring	Duplex				x									
63	1	Spring guide	PP				x									
64	1	Retainer ball	Super Duplex / DLC				x									
65	1	Retainer plate	Super Duplex				x									
66	9	Piston	Super Duplex / PEEK					x	x	x						
67	1	Key (12x8x70)	AISI 316	x												
71	1	Retainer guide	Super Duplex / PEEK				x									
91	1	Port plate	Super Duplex / PEEK			x										
92	1	Valve plate	Super Duplex			x										
93	9	Back-up ring	PEEK	x		x										
94	9	O-ring (Ø30.2x3)	NBR	x		x										
121	1	Port flange	Duplex / PEEK													
122	1	O-ring (Ø68x2)	NBR	x												
123	1	O-ring (Ø228x4)	NBR	x												
124	1	Shaft seal	Hastelloy / NBR	x												
125	1	Cover for shaft seal	Super Duplex													
126	2	Pin (Ø10.5x20)	Duplex	x												
127	4	Screw (M6x16)	AISI 316	x												
128	15	Screw (M8x90)	AISI 316	x												
142	1	Stop for shaft seal	PP	x												
144	4	Tailstock screw (M12x60)	AISI 316													
145	4	Check nut (M12)	AISI 316	x												
146	1	Lifting eye	AISI 316													
147	1	Screw (M8x16)	AISI 316	x												
151	1	O-ring (Ø35x3)	FPM 75	x												x
152	1	Valve cone	Super Duplex													x
153	1	Spring (Ø1.9xØ25x33.7)	Duplex													x
154	1	Plug/guide	Super Duplex													x
155	1	O-ring (Ø47.22x3.53)	NBR	x												x
		Instruction		x	x	x	x	x	x	x	x	x	x	x	x	x

21. Exploded view
APP 21 - 26

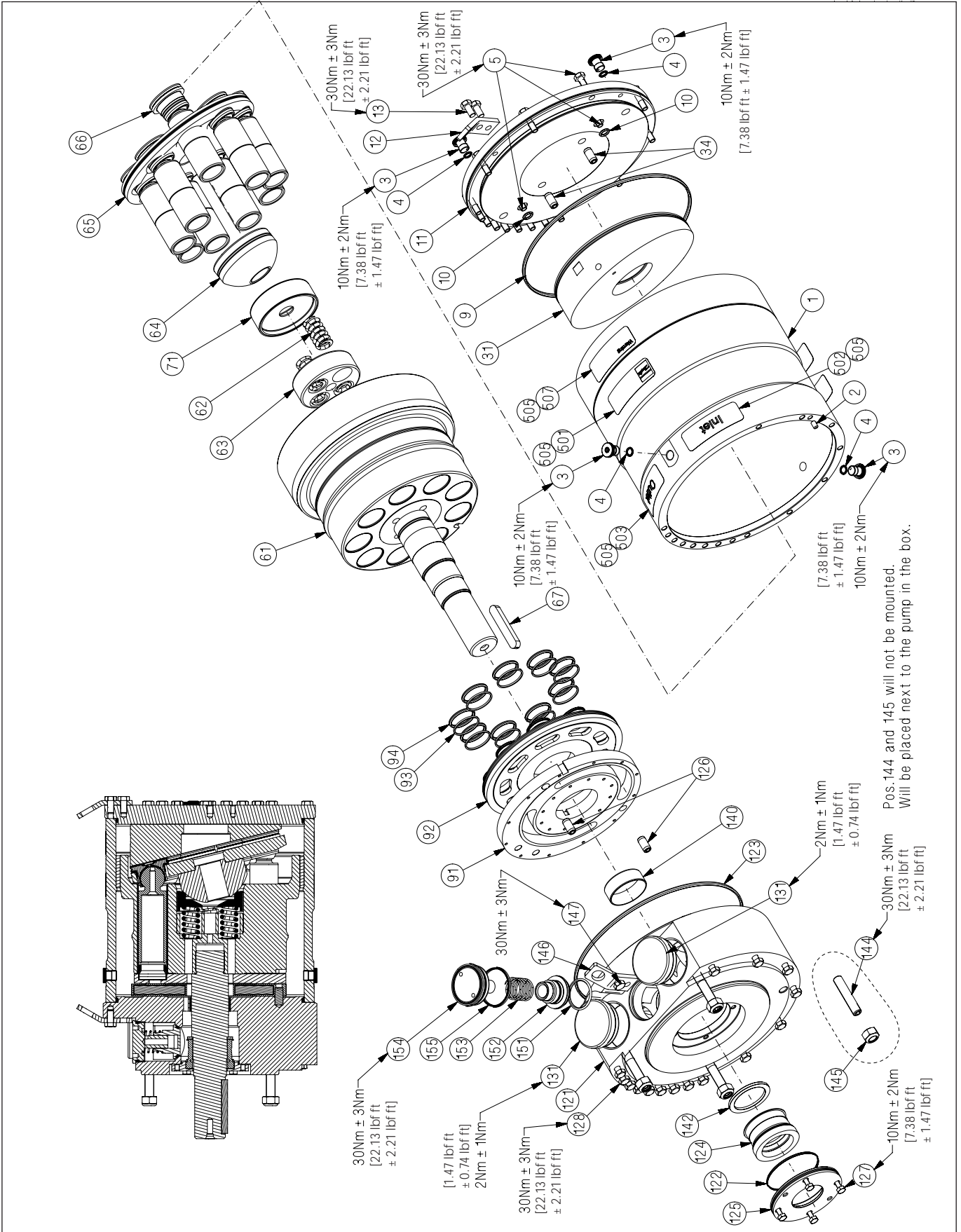

Parts list

APP 0.6-43 / APM 0.8-2.9 / APP W 5.1-10.2

22. Parts list
APP 30 - 43

Note:
The parts listed are not sold separately, only in various kits.

Exploded view, see next page.

Pos.	Qty.	Designation	Material	180B4171 – Seal set (APP 30-43)	180B4166 – Cylinder barrel (APP 30-43)	180B4180 – Valve plate set (APP 30-43)	180B4179 – Retainer set (APP 30 / 1200 rpm and APP 38 / 1500 rpm)	180B4164 – Retainer set (APP 30 / 1500 rpm)	180B4383 – Retainer set (APP 43 / 1700 rpm)	180B4199 – Piston set (APP 30-43)	180B4178 – Swash plate set (APP 30 / 1,200 rpm, APP 38 / 1500 rpm and APP 43 / 1700 rpm)	180B4168 – Swash plate set (APP 30 / 1500 rpm)	180B4170 – Flushing valve set (APP 30-43)
1	1	Housing	Duplex / PEEK										
2	2	Pin (Ø6x10)	AISI 316	x									
3	2	Bleeding plug	Super Duplex	x									
4	4	O-ring (Ø11x2)	NBR	x									
5	17	Screw (M8x30)	AISI 316	x						x			
9	1	O-ring (Ø228x4)	NBR	x						x			
10	2	O-ring (Ø9.19x2.62)	NBR	x							x	x	
11	1	End flange	Duplex										
12	1	Lifting eye	AISI 3169										
13	1	Screw (M8x16)	AISI 316	x									
31	1	Swash plate	Super Duplex								x	x	
34	2	Pin (Ø10.5x20)	Duplex	x							x	x	
61	1	Cylinder barrel	Super Duplex / PEEK		x								
62	4	Spring	Duplex				x	x	x				
63	1	Spring guide	PP				x	x	x				
64	1	Retainer ball	Super Duplex / DLC				x	x	x				
65	1	Retainer plate	Super Duplex				x	x	x				
66	9	Piston	Super Duplex / PEEK							x			
67	1	Key (12x8x70)	AISI 316	x									
71	1	Retainer guide	Super Duplex / PEEK				x	x	x				
80	4	Spacer	Super Duplex										
91	1	Port plate	Super Duplex / PEEK			x							
92	1	Valve plate	Super Duplex			x							
93	9	Back-up ring	PTFE	x		x							
94	9	O-ring (Ø30.2x3)	NBR	x		x							
121	1	Port flange	Duplex / PEEK										
122	1	O-ring (Ø68x2)	NBR	x									
123	1	O-ring (Ø228x4)	NBR	x									
124	1	Shaft seal	Hastelloy / NBR	x									
125	1	Cover for shaft seal	Super Duplex										
126	2	Pin (Ø10.5x20)	Duplex	x									
127	4	Screw (M6x16)	AISI 316	x									
128	15	Screw (M8x90)	AISI 316	x									
142	1	Stop for shaft seal	PP	x									
144	4	Tailstock screw (M12x60)	AISI 316										
145	4	Check nut (M12)	AISI 316	x									
146	1	Lifting eye	AISI 316										
147	1	Screw (M8x16)	AISI 316	x									
151	1	O-ring (Ø35x3)	FPM 75	x									x
152	1	Valve cone	Super Duplex										x
153	1	Spring (Ø1.9xØ25x33.7)	Duplex										x
154	1	Plug/guide	Super Duplex										x
155	1	O-ring (Ø47.22x3.53)	NBR	x									x
		Instruction		x	x	x	x	x	x	x	x	x	x

23. Exploded view
APP 30/1200 and APP 43/1700

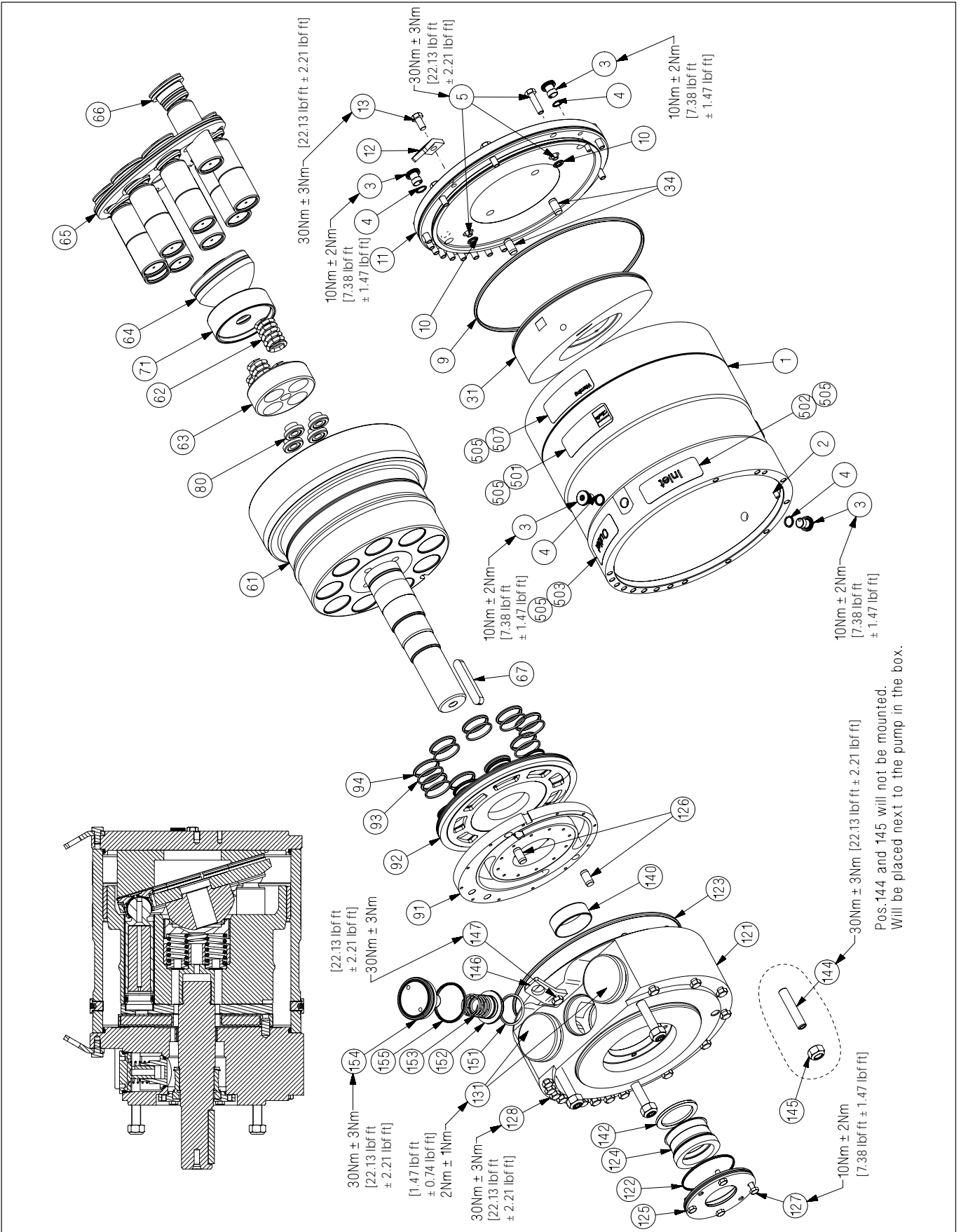

24. Tool sets

Note:
The parts listed are not sold separately, only in various kits.

Designation	180B4188 – Tool set (APP 0.6-1.0 Compact)	180B4142 – Tool set (APP 0.6-1.0)	180B4148 – Tool set (APP 1.5-3.5)	180B4162 – Tool set (APP 5.1-10.2)	180B4230 – Tool set (APP 11-13)	180B4222 – Tool set (APP 16-22)	180B4172 – Tool set (APP 21-43)
Shaft bush	x						
Press bush	x						
Drift	x						
Torx (T30)	x						
Shaft bush (Ø18)		x	x				
Press bush (Ø18)		x	x				
Allen key (4 mm)		x					
Allen key (5 mm)			x				
Allen key (6 mm)				x	x	x	x
Shaft bush (Ø35)				x			
Shaft seal extractor (Ø35)				x	x		
Press bush (Ø35)				x	x		
Adjustable pin wrench				x	x	x	x
Combination wrench (10 mm)				x	x	x	x
Combination wrench (13 mm)					x	x	x
Nut (M8x6.5x13)					x	x	x
Guide bolt (M8x140)					x		x
Shaft seal extractor (Ø45)						x	x
Press bush (Ø45)						x	x
Eye bolt (M8)					x	x	
Press bush for valve plate						x	x
Stop for retainer plate							x
Screw (M8x20)					x	x	x
Screw (M8x70)						x	x

Danfoss A/S
High Pressure Pumps
DK-6430 Nordborg
Denmark

Danfoss can accept no responsibility for possible errors in catalogues, brochures and other printed material. Danfoss reserves the right to alter its products without notice. This also applies to products already on order provided that such alterations can be made without subsequential changes being necessary in specifications already agreed. All trademarks in this material are property of the respective companies. Danfoss and the Danfoss logotype are trademarks of Danfoss A/S. All rights reserved.

Guideline

Trouble shooting guide for APP and APP S 674 pumps



Table of Contents

Trouble shooting fish bone chart

**Trouble shooting guide for
APP and APP S 674 pumps**

1. No flow/no pressure
2. Reduced flow/reduced pressure
3. High torque on electric motor
4. Noise from pump
5. Noise from installation
6. Typical signs of wear
 - 6.1 Valve plate
 - 6.2 Port plate
 - 6.3 Swash plate

Trouble shooting fish bone chart

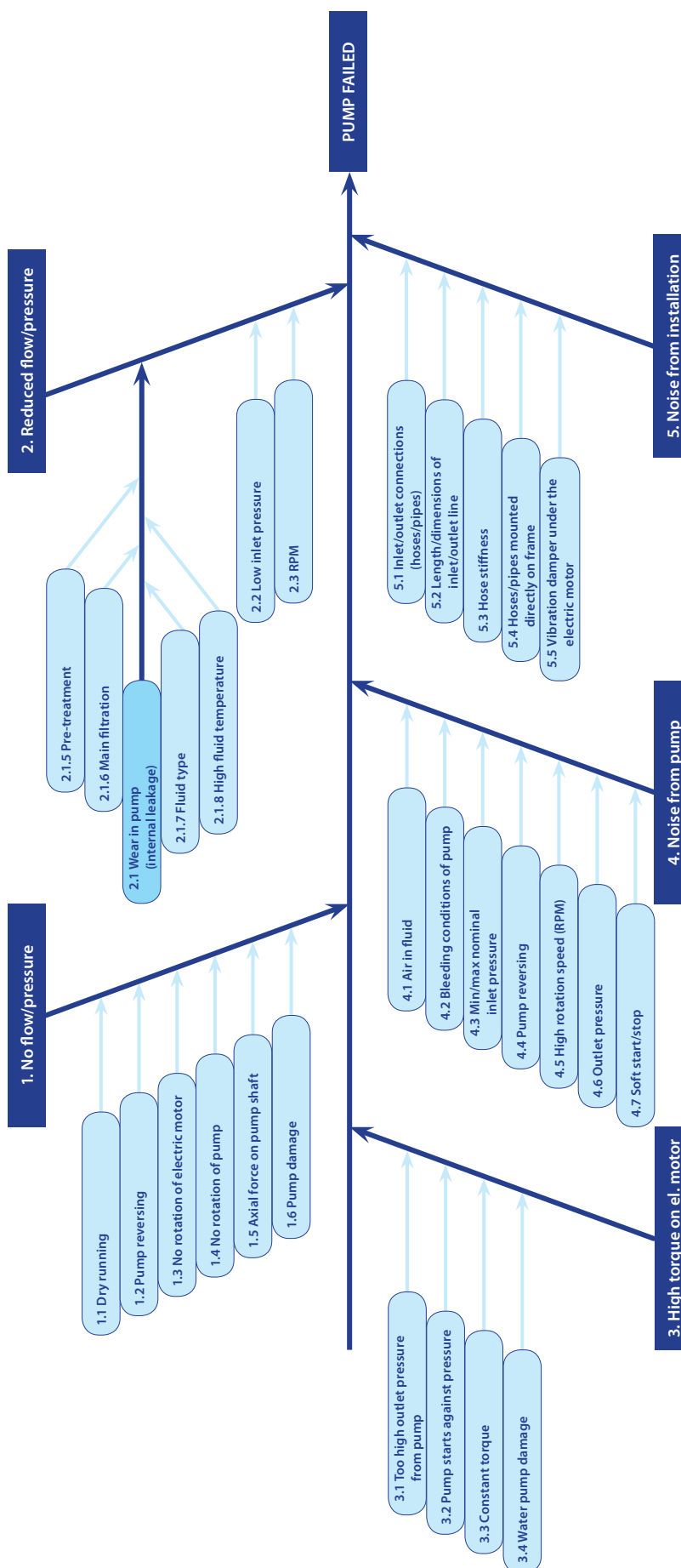

1. No flow/no pressure

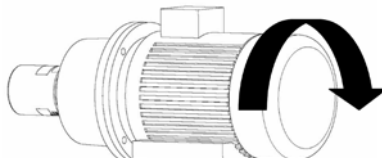
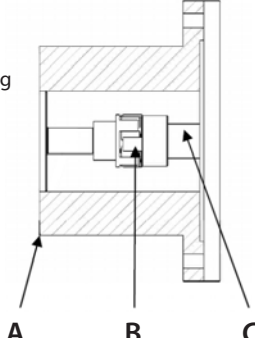
Cause	Remedy	Comments
<p>1.1 Dry running (no water supply to the pump)</p>	<p>If no water comes out of the pump:</p> <p>1.1.1 Check that inlet valve is open. 1.1.2 Check that booster pump is running.</p>	<p>Mount a low pressure switch in front of the pump and check its set point/ function. The low pressure switch ensures that the pump does not start until the inlet pressure has reached minimum inlet pressure (see User manual).</p>
<p>1.2 Pump reversing (electric motor is running the wrong direction, i.e. counter-clockwise)</p>	<p>1.2.1 Change the phase on the electric motor to make it run clockwise.</p> <p>WARNING: - The pump must not run without water for more than a few seconds. - If the pump takes in water from the high-pressure outlet line, it builds up pressure in pump housing and will eventually break down.</p>	<p>Rotation direction for the APP or APP S 674 pump is shown by an arrow on the label on the pump.</p> 
<p>1.3 No rotation of electric motor</p>	<p>1.3.1 Check that main switch is switched on. 1.3.2 Check the electricity at the facility. 1.3.3 Ensure that motor relay is switched on. 1.3.4 Ensure that fuse is not blown. 1.3.5 Ensure that booster pump is started. 1.3.6 Check that the monitor switches are working correctly. 1.3.7 Disconnect pump from electric motor and check that the motor is capable of running with no load.</p>	<p>If motor-type relay or the electrical fuse is blown, check that electric motor is sized correctly.</p>
<p>1.4 No rotation of pump</p>	<p>1.4.1 Ensure that coupling between electric motor and pump is connected. 1.4.2 Check if coupling is damaged. 1.4.3 Check that electric motor is sized correctly. 1.4.4 Check that the electrical installation is correctly sized. 1.4.5 Contact Danfoss Sales office for guidelines in how to troubleshoot internal pump parts.</p>	
<p>1.5 Axial load on pump shaft (may cause high internal leakage) Only applying to APP 0.6 to APP 3.5 and APP 21 to APP 26 only. Also applying to APP S 674 pumps.</p>	<p>1.5.1 Ensure that the air gap between the two coupling parts is min 5 mm. It should always be possible to move the plastic part on the coupling at least 3 mm.</p>	<p>To ensure easy mounting of the flexible coupling without using tools, the tolerances must be dimensioned accordingly.</p> <p>WARNING: Any axial and/or radial loads on the shaft must be avoided. Any axial or radial load will cause breakdown.</p>  <p>A - Bell housing B - Flexible coupling C - Motor shaft</p>
<p>1.6 Pump damage (the internal parts may be damaged)</p>	<p>1.6.1 Contact Danfoss sales office for guidelines in how to troubleshoot internal pump parts.</p>	<p>Instructions on internal elements 180R9092/180R9085 for APP 0.6-1.0 180R9091/180R9147/180R9089 for APP 1.5-3.5 180R9093/180R9090 for APP 5.1-10.2 180R9228/180R9227 for APP 11-13 and APP 16-22 180R9121/180R9139 for APP 21-43 180R9281 for APP S 674 3.0-3.5 180R9280 for APP S 674 5.1-9.0 180R9278 for APP S 674 21-38 - are available on www.ro-solutions.com.</p>

2. Reduced flow/reduced pressure

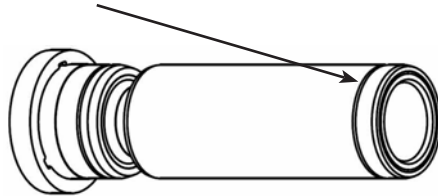
Cause	Remedy	Comments
<p>2.1 Wear on pump Large internal leakage due to:</p>	<p>2.1.1 Dismantle the pump. 2.1.2 Check valve plate. Valve plate has marks/scratches on the surface facing the port plate. Minor wear on valve plate can cause large internal leakage. See Index 6.1. 2.1.3 Check port plate. Port plate has marks/scratches on the surface facing the valve plate. Minor wear on port plate can cause large internal leakage. See Index 6.2. 2.1.4 Check cylinder barrel. Liners in cylinder barrel may be scratched or worn. Insert a piston in the liner and check the fit. If there is any space (clearance) between liner and piston, liner or piston is worn. 2.1.5 Pre-treatment Analyse fluid for content of particles. - Check that filters are OK and working correctly. 2.1.6 Main filtration Check that the correct filter type is used (particles in fluid must not exceed 10 µm). Danfoss High Pressure Pumps supplies filters, please contact the sales office. 2.1.7 Fluid type The APP and APP S 674 pumps are designed for seawater operation; for any other fluid, please contact Danfoss High Pressure Pumps sales office for further help. 2.1.8 High fluid temperature If fluid temperature is above 50°C, stop the pump immediately.</p> <p>- Check internal parts (see above).</p>	<p>Typical signs of wear: Polished surface all over the swash plate. Normally, only half of the swash plate = the pressure side is polished. See index 6.3.</p> <p>If the ring is missing, the piston is very worn.</p>  <p>The filters can be bypassed, even if they are correctly mounted. Some filters can create channelling where particles can pass through the filter in tunnels. String wounded filters are typically channelling filters. A string wounded filter may have a filtration efficiency of only 50%, which will cause internal wear and must always be followed by a main filter.</p> <p>Insufficient filtration means that too many or too large hard particles can pass the main filter because it is damaged, bypassed or simply too poor. Filtration efficiency must be 99.98% (Beta = 5000) at 10 µm to prevent abnormal wear of the pump.</p> <p>Temperature > 50°C will cause wear on internal pump parts. Mount a temperature switch and check its set point / function. The temperature switch will ensure that the pump stops at fluid temperatures > 50°C.</p>
<p>2.2 Low inlet pressure</p>	<p>2.2.1 Check that booster pump supplies the right pressure/flow. 2.2.2 Check if filters require replacement.</p>	<p>If the pressure drop across the filters is too high, the booster pump does not deliver sufficient flow/pressure. No pressure or low pressure results in cavitation and insufficient internal lubrication causing wear on internal pump parts.</p> <p>Mount a low-pressure switch in front of the pump and check its set point/ function. The low-pressure switch ensures that the pump does not start until the inlet pressure has reached 1 bar.</p>
<p>2.3 Rotation speed (rpm)</p>	<p>2.3.1 If VFD-operated, check frequency. 2.3.2 Check that rotation speed of the electric motor is as stated on name plate on electric motor. Check that the motor rotor winding is not damaged.</p>	<p>Speeds below min. limit (see User manual) result in insufficient internal lubrication causing wear on the internal pump parts.</p>

4. Noise from pump

Cause	Remedy	Comments
4.1 Air in fluid	4.1.1 Ensure that the entire inlet line is bled before starting up the system. 4.1.2 Ensure that air cannot enter into the inlet line.	Small air bubbles will accumulate and create large bubbles causing internal cavitation and thus making the pump very noisy. WARNING: The pump can only run few minutes with air in the fluid without being damaged.
4.2 Bleeding conditions of pump	4.2.1 Follow the instructions "Initial start-up" supplied with the new pump. 4.2.2 Ensure that the pump is completely bled before start-up.	The pump and the inlet line must be completely bled before start-up, otherwise the pump will cavitate and make high noise. WARNING: The pump can only run few minutes with air in the fluid without being damaged.
4.3 Min/max nominal inlet pressure	4.3.1 Ensure that inlet pressure is within the limits specified in the User manual. 4.3.2 Check the pump for internal damage.	Too high inlet pressure causes too high pressure inside the pump damaging the pistons and eventually the pump. Inlet pressure below min. limit causes cavitation and insufficient internal lubrication resulting in wear on internal pump parts. Mount a low-pressure switch in front of the pump and check its set point/ function. The low-pressure switch will ensure that the pump does not start until the min. inlet pressure has been reached.
4.4 Pump reversing	4.4.1 Dismantle pump and check if anything is broken or worn (See "1. No flow", item 1.2 Pump reversing"). WARNING: The pump must not run without water for more than a few seconds. If the pump takes in water from the high-pressure outlet line, it builds up pressure and will eventually be damaged.	If pump rotates in wrong direction, it will take in water from the high-pressure outlet line. Pressure will be built up inside the pump and it will eventually be damaged.
4.5 High rotation speed (rpm)	4.5.1 If electric motor rpm is too high, dismantle pump and check for damage. 4.5.2 If the rpm is within the specified range of the pump data sheet and abnormal noise remains, dismantle pump and check for damage.	Higher rpm than specified in the pump data sheet results in wear of the pistons, i.e. pistons may be damaged. High rpm will also increase pressure pulsations from the pump, and the noise level will increase. If rpm is changed, noise frequency will also change.
4.6 Outlet pressure	4.6.1 If outlet pressure is too low, check set point of outlet pressure valve. 4.6.2 If outlet pressure is lower than mentioned in the pump data sheet, please contact Danfoss High Pressure Pumps technical support. 4.6.3 If outlet pressure has exceeded its maximum, check set point of outlet pressure valve. 4.6.4 Check internal parts for wear/damage.	At too low outlet pressure, the pump will create higher pressure pulsations and thus make noise. Too low pressure also causes insufficient internal lubrication and wear on internal parts. Pump may eventually be damaged. Too high outlet pressure may damage the pump.
4.7 Soft start/stop	4.7.1 Check if noise is normal when the pump is running at operation speed. 4.7.2 If noise is abnormal at operation speed, check internal parts (see above).	Noise frequency changes during soft start-up/ stop.

Instruction **Trouble shooting guide for APP and APP S 674 pumps**

5. Noise from installation

Cause	Remedy	Comments
5.1 Inlet/outlet connections (hoses/pipes)	5.1.1 Use flexible hoses at inlet/outlet connections. Danfoss can provide flexible hoses. Please contact Danfoss High Pressure Pumps sales office for further information. 5.1.2 Mount the connections to the frame by a vibration dampener mounting plate.	Non-flexible connections mounted directly on the frame will cause even small pressure pulsations from pump and create vibrations in the system/plant.
5.2 Length/dimension of inlet/outlet line	5.2.1 Increase pipe diameter and/or reduce the number of bends.	Too small pipes or too many bends may create too fast flow/turbulence through the pipes and thus increase the noise level.
5.3 Hose stiffness	5.3.1 Use a more flexible hose. Danfoss can provide flexible hoses. Please contact Danfoss High Pressure Pumps sales office for further information.	Too stiff hoses cannot dampen the small pressure pulsations from the pump, and subsequently vibrations occur in the system/plant.
5.4 Hoses/pipes mounted directly on frame	5.4.1 Mount the connections to the frame by a vibration dampener mounting plate.	If the hoses are mounted directly on the frame, the small pressure pulsations from the pump can be transferred to the frame and the rest of the system/plant.
5.5 Vibration dampener under the electric motor	5.5.1 Mount a vibration dampener below the motor/pump.	When no dampener is installed below the electric motor, vibrations from the motor and pump may be transferred to the frame and the rest of the system/plant.

6. Typical signs of wear

6.1 Valve plate

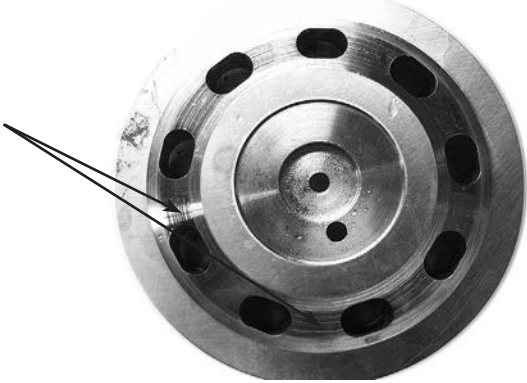
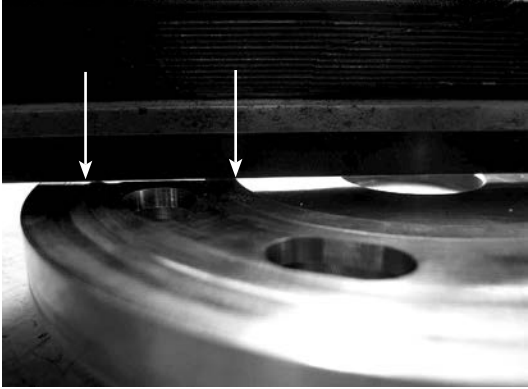
<p>Picture 1</p> 	<p>A normally worn valve plate has no marks/scratches but only a slightly polished surface.</p> <p>No scratches or marks should be felt. The surface must be flat and level.</p>
<p>Picture 2</p> <p>Scratches</p> 	<p>A worn valve plate has scratches, and/or a polished surface. Even small scratches will give a loss of flow.</p>
<p>Picture 3</p> 	<p>A good way to identify a worn valve plate is to hold a straight knife edge over the valve plate. When holding it up to the light, it will be possible to see any space between the knife edge and the valve plate. See picture 3.</p> <p>If any light can be seen between the two arrows on the picture, the valve plate is worn.</p> <p>If any scratches or marks can be felt by running a fingernail over the surface, the valve plate is worn.</p> <p>The valve plate on picture 3 is highly damaged.</p>

6. Typical signs of wear

6.1 Valve plate

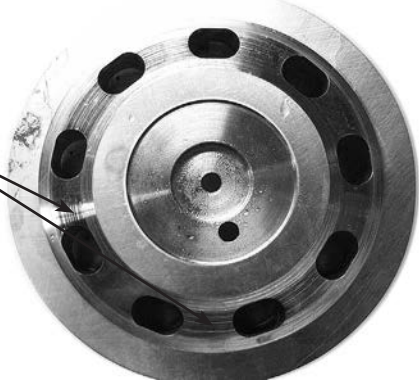
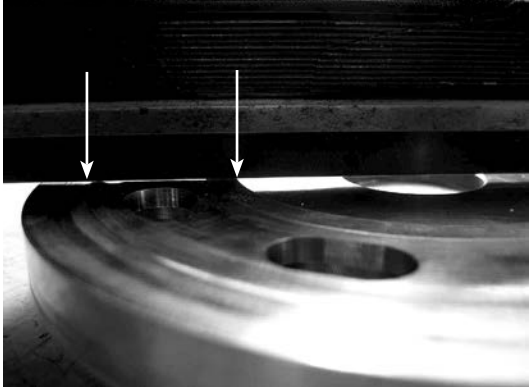
<p>Picture 1</p> 	<p>A normally worn valve plate has no marks/scratches but only a slightly polished surface.</p> <p>No scratches or marks should be felt. The surface must be flat and level.</p>
<p>Picture 2</p> <p>Scratches</p> 	<p>A worn valve plate has scratches, and/or a polished surface. Even small scratches will give a loss of flow.</p>
<p>Picture 3</p> 	<p>A good way to identify a worn valve plate is to hold a straight knife edge over the valve plate. When holding it up to the light, it will be possible to see any space between the knife edge and the valve plate. See picture 3.</p> <p>If any light can be seen between the two arrows on the picture, the valve plate is worn.</p> <p>If any scratches or marks can be felt by running a fingernail over the surface, the valve plate is worn.</p> <p>The valve plate on picture 3 is highly damaged.</p>

Right and wrong

Trouble shooting guide for water hydraulic systems

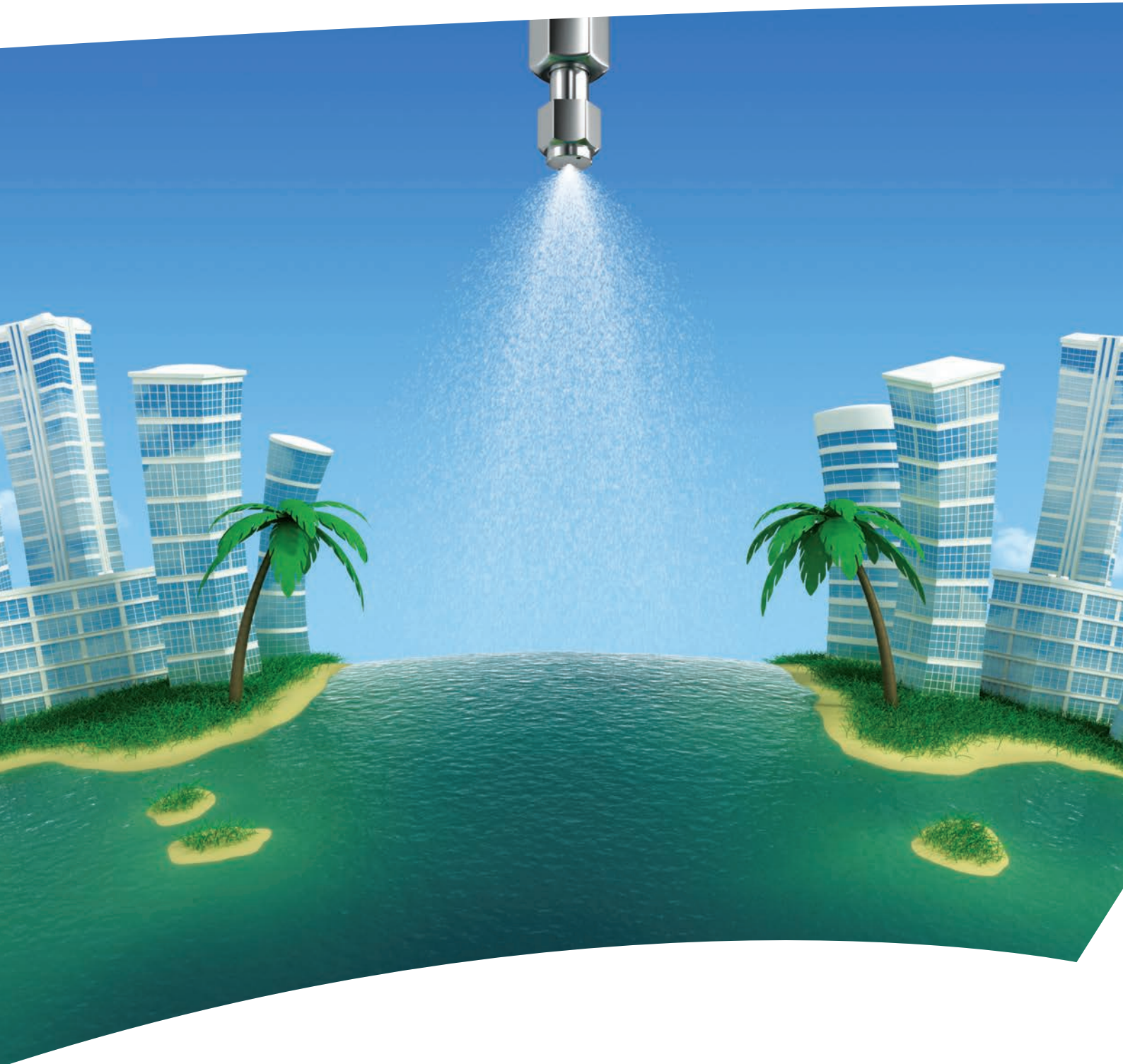

Design

1. Choice of material

- Rubber
- Plastic
- Stainless steel

Always use system components made of corrosion proof materials

- Iron
- Copper
- Brass
- Aluminium

Non-corrosion proof materials may cause damage

2. Choice of filter

< 10 µm abs.

Install a 10 micron absolute filter with pressure switch

> 10 µm

Return filter with bypass valve and poorer filterability than 10 µm will damage the system

3. Filter location

Locate the return filter in the return line immediately before the tank

Placing the return filter upstream of the final load may damage the pump

4. Pump location

Pump always to be placed below water surface level

Pump location above water surface level will cause damage

5. Suction conditions

System to be dimensioned to provide a suction pressure of the pump inlet of max. 0.1 bar vacuum

Poor suction conditions will cause malfunction and damage the pump

6. Pressure Relief valve

Pressure relief valve to be mounted vertically or with vertical outlet and connected to return hose or tank

Coupling the pressure relief valve outlet directly to the pump inlet may damage the pump

7. Water supply

System to be filled via filter

Filling system with unfiltered water causes damage

Installation

8. Impurities

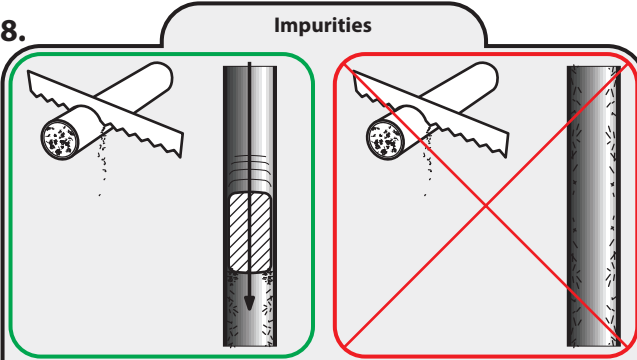

Prior to installation, burrs and chips and other impurities must be removed from pipes and hoses, eg with a felt plug

Chips or other impurities in the system may cause damage

11. Assembly of coupling

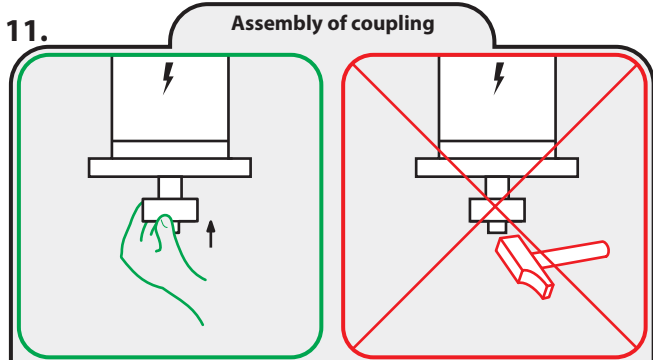

The coupling must be easy and simple to assemble (see product instruction)

Never use force when assembling the coupling parts, as this will damage the motor/pump

9. Sealing

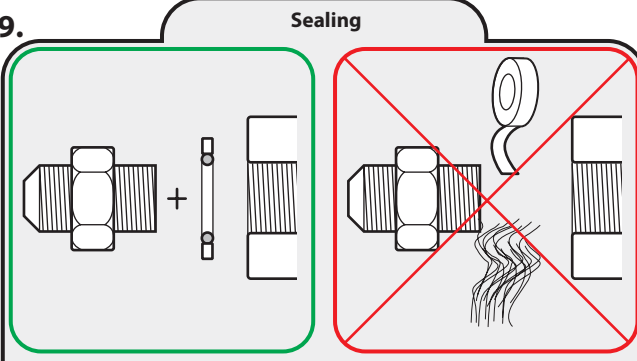

Fittings in screwed components to be sealed with O-rings or bonded seals

Using teflon tape or packing yarn in joints may cause damage

12. Coupling

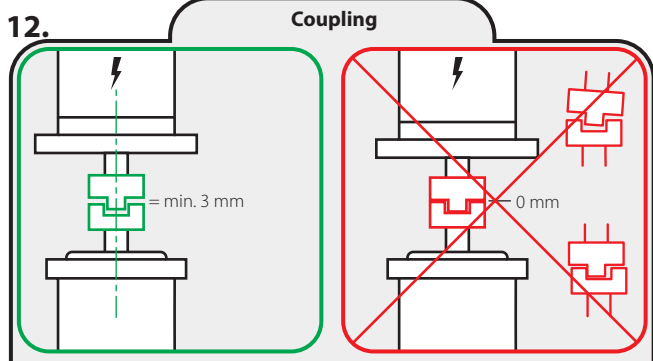

Ensure always to have 3 mm distance between coupling flanges

Insufficient distance and/or misalignment between the coupling flanges will damage the pump

10. Grease

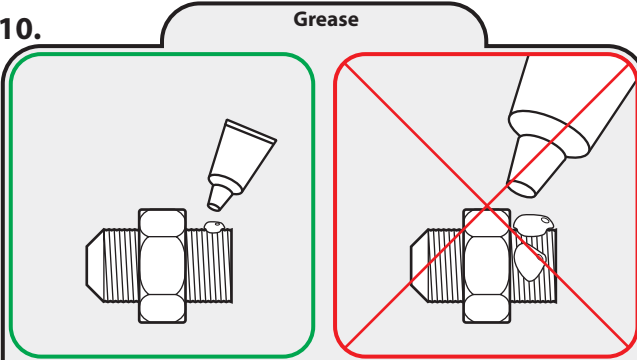

Correctly limited quantities of grease prevent seizing

Too much grease may develop biofilm causing operational failures

13. Water supply

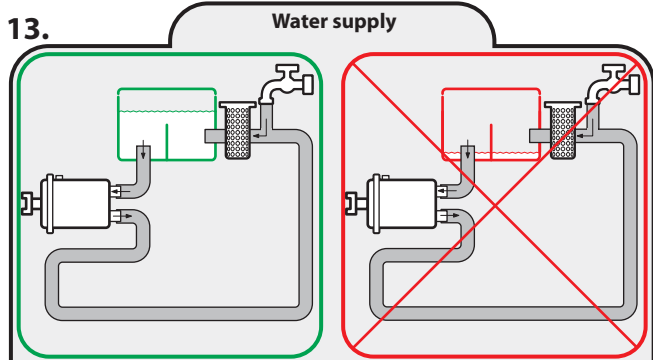

Fill system with water before starting to ensure lubrication and cooling

Starting without water will cause damage

Wiring

14.

Level indicator

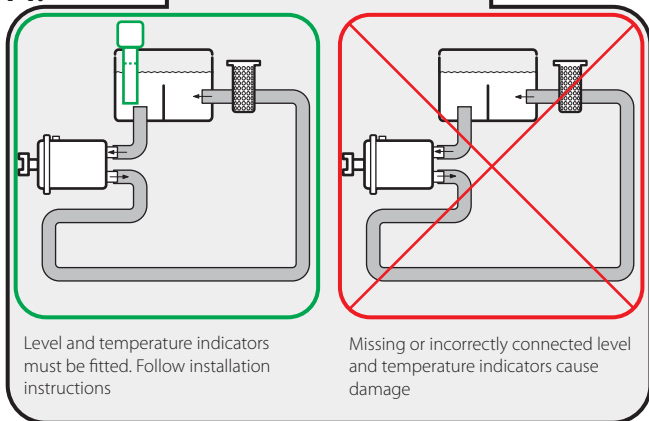

15.

Rotation direction

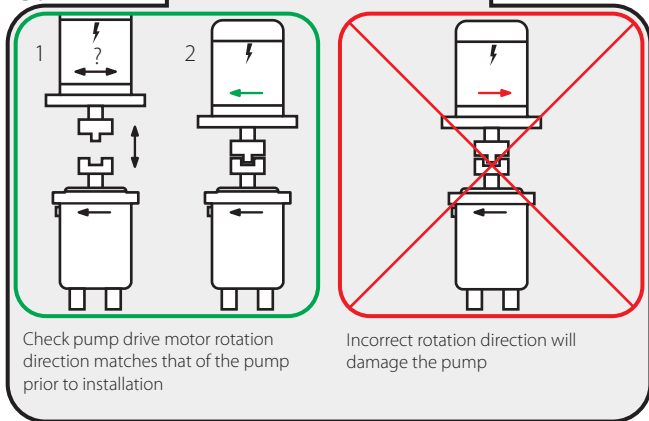

16.

Bleeding

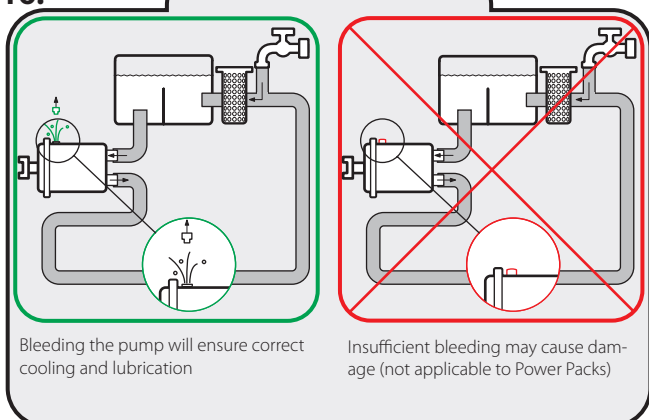

Starting procedure

Cleaning procedure

1. Fill cold water into the system via the return filter and bleed the pump (Power Packs PPH 4 - 6.3 - 10 and 12.5 are self-bleeding)
2. Start and bleed the system -without pressure by opening the bypass valve
3. Add the cleaning agent to give 3% agent/water solution
4. Run the system for 60 min. and activate all components as often as possible to ensure effective flushing with the cleaning agent
5. Empty the system of the cleaning agent solution

Flushing procedure

6. Fill cold water through the return filter and bleed the pump (Power Packs PPH 4 - 6.3 - 10 and 12.5 are self-bleeding)
7. Run the system for 30 min. and activate all components as often as possible
8. Empty the system of the water
9. Alternatively the system may be flushed by running the unit without the return hose while continuously filling up water. The flushing should continue until there is no trace of cleaning agent in the return water
10. Change the return filter element, fill cold water through the return filter and bleed the pump during start up
11. The system is now ready for operation

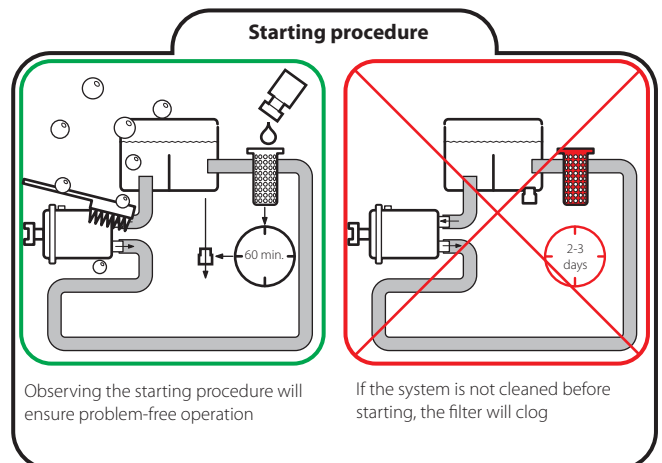

Trouble shooting

Open ended water systems

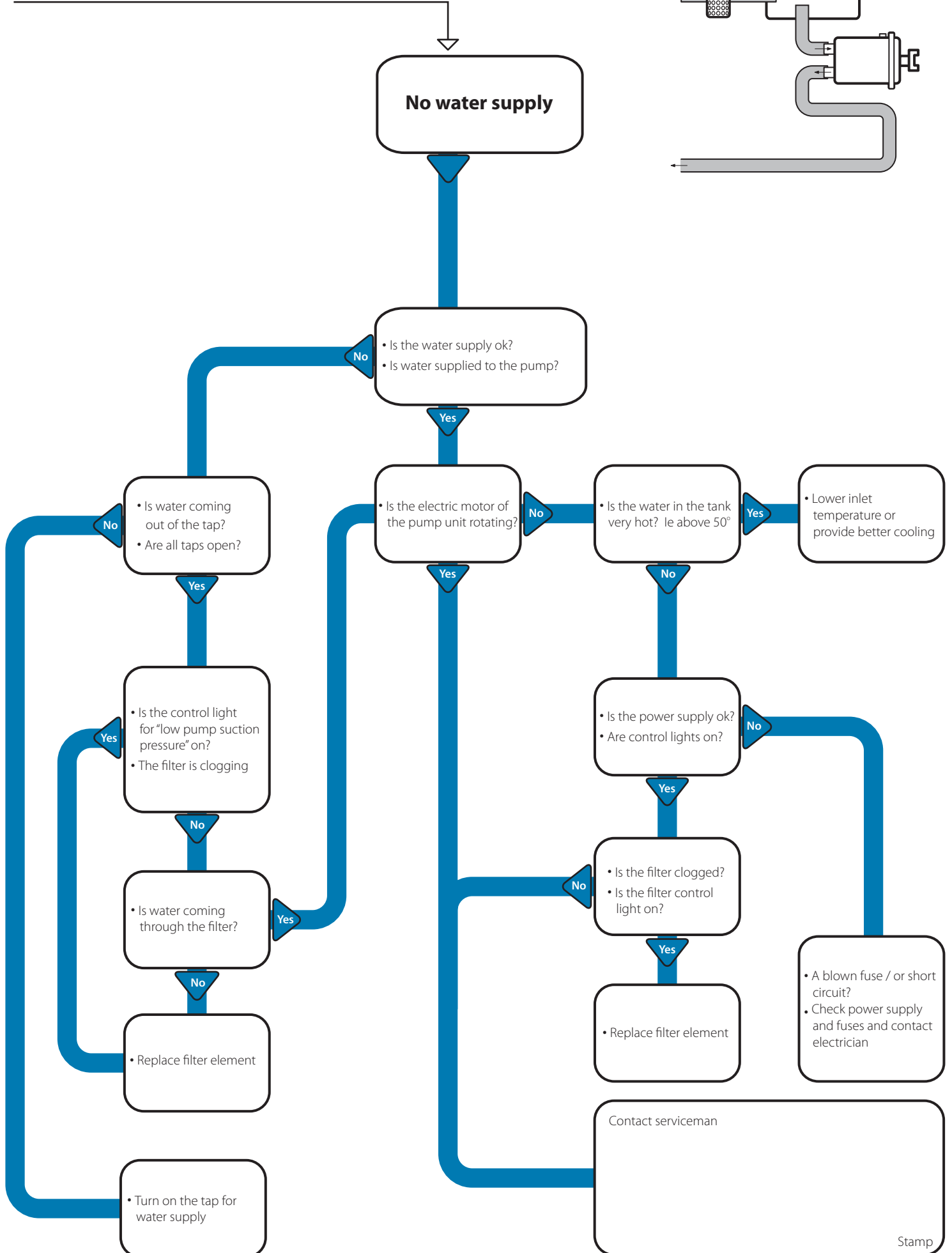
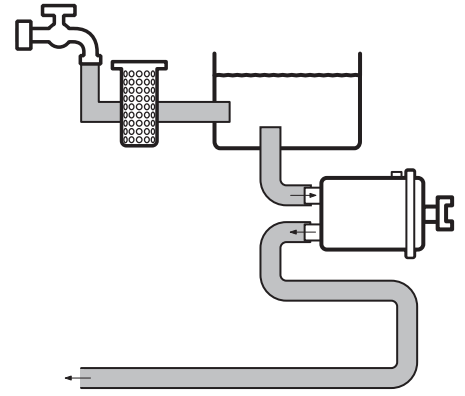

Trouble shooting

Closed water systems

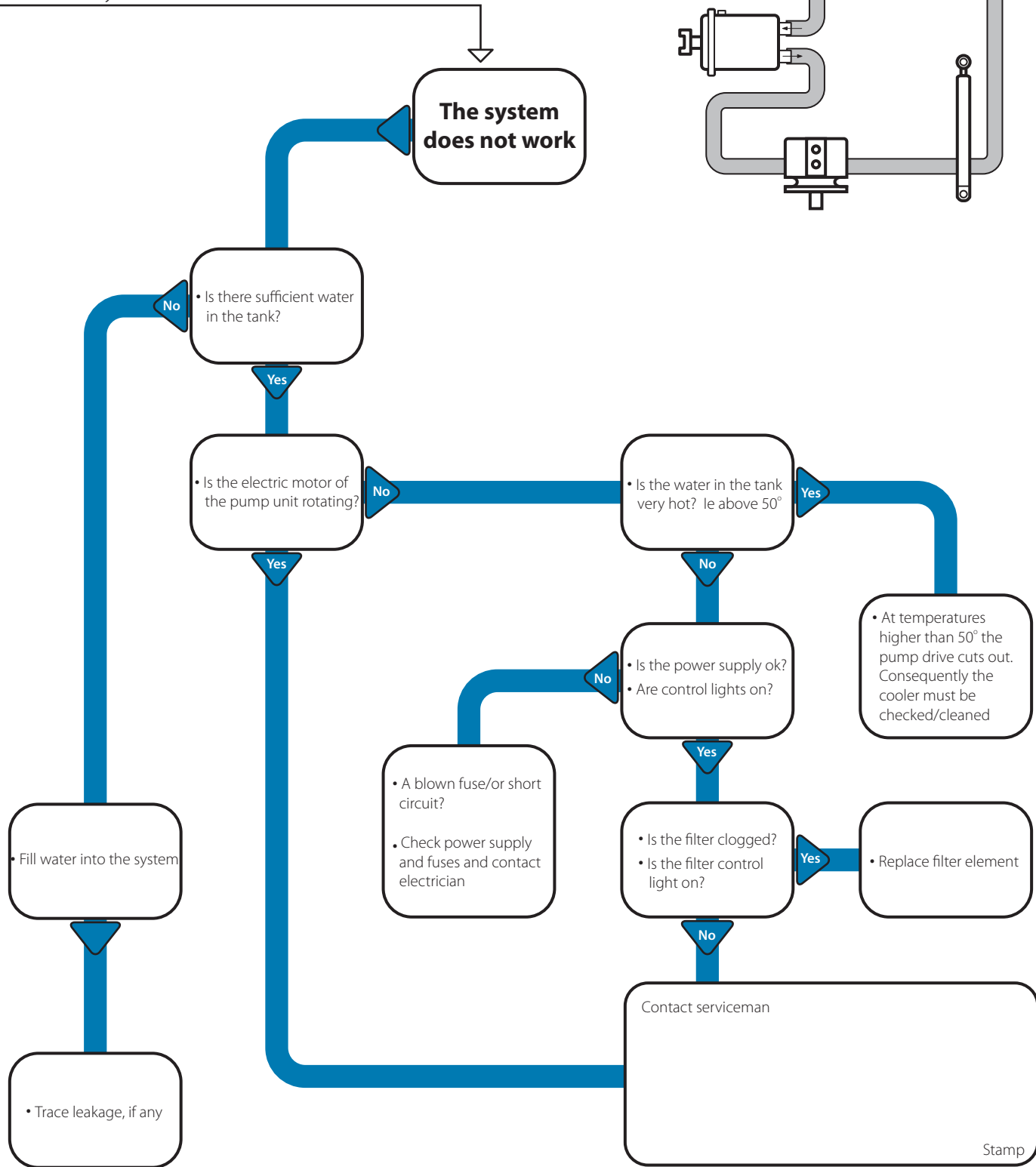
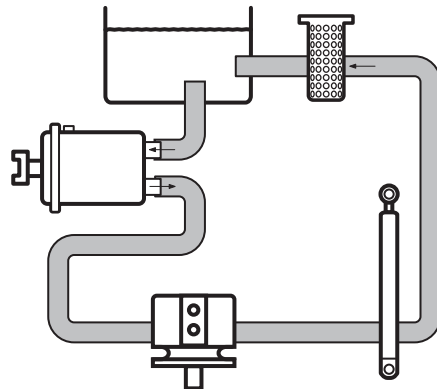

Danfoss can accept no responsibility for possible errors in catalogues, brochures and other printed material. Danfoss reserves the right to alter its products without notice. This also applies to products already on order provided that such alterations can be made without subsequential changes being necessary in specifications already agreed. All trademarks in this material are property of the respective companies. Danfoss and the Danfoss logotype are trademarks of Danfoss A/S. All rights reserved.



Danfoss A/S
High Pressure Pumps
DK-6430 Nordborg
Denmark

Danfoss can accept no responsibility for possible errors in catalogues, brochures and other printed material. Danfoss reserves the right to alter its products without notice. This also applies to products already on order provided that such alterations can be made without subsequential changes being necessary in specifications already agreed. All trademarks in this material are property of the respective companies. Danfoss and the Danfoss logotype are trademarks of Danfoss A/S. All rights reserved.
