

38 Frame Block-Style Stainless Steel Plunger Pump

**Standard
Models**

3841

**Flushed
Models**

3841K

FEATURES

Superior Design

- Triplex plunger design provides smoother liquid flow.
- Oil bath crankcase assures optimum lubrication.
- Close tolerance concentricity of the ceramic plunger maximizes seal life.
- **Standard Models:** Lo-Pressure Seals and V-Packings are completely lubricated and cooled by the liquid being pumped.
- **K Models:** Special Flushed Inlet Manifold permits flush for added cooling with high temperature liquids and lubrication with low lubricity liquids.

Quality Materials

- Precision design 316 stainless steel valves are hardened and polished for ultimate seating and extended valve life.
- 316 SSL block-style manifolds for strength and corrosion resistance.
- Special concentric, high-density, polished, solid ceramic plungers provide a true wear surface and extended seal life.
- Specially formulated, CAT PUMP exclusive, V-Packings offers unmatched performance and seal life.
- Die cast aluminum crankcase provides high strength, minimum weight and precision tolerance control.
- Optional Cast Iron crankcase for hazardous environments.
- Chrome-moly crankshaft gives unmatched strength and surface hardness.
- Oversized crankshaft bearings with greater loading capacity means longer bearing life.

Easy Maintenance

- Wet-end is easily serviced without entering crankcase, requiring less time and effort.
- Inlet and discharge valve assemblies interchange for easier maintenance without disturbing piping.
- Preset packings mean no packing gland adjustment is necessary, reducing maintenance costs.

⚠ WARNING

All systems require both a primary pressure regulating device (i.e., regulator, unloader) and a secondary pressure safety relief device (i.e., pop-off valve, safety valve). Failure to install such relief devices could result in personal injury or damage to the pump or to system components. CAT PUMPS does not assume any liability or responsibility for the operation of a customer's high pressure system.

SPECIFICATIONS

	U.S. Measure	Metric Measure
Flow.....	45 GPM	(170 L/M)
Pressure Range.....	100 to 1000 PSI	(7 to 70 BAR)
Inlet Pressure Range*.....	Flooded to 70 PSI	(Flooded to 4.9 BAR)
RPM.....	765 RPM	(765 RPM)
Bore.....	1.772"	(45 mm)
Stroke.....	1.890"	(48 mm)
Crankcase Capacity.....	4.2 Qts.	(4 L)
Maximum Liquid Temperature.....	140°F	(60°C)
Above 130°F call CAT PUMPS for inlet conditions and elastomer recommendations.		
Inlet Ports (2).....	1-1/2" NPTF	(1-1/2" NPTF)
Flushing Ports (2)*.....	1/2" NPTF	(1/2" NPTF)
Discharge Ports (2).....	1" NPTF	(1" NPTF)
Shaft Diameter.....	1.378"	(35 mm)
Weight.....	139 lbs.	(63 kg)
Dimensions.....	24.8 x 18.11 x 9.37"	(620 x 460 x 238 mm)

* K Models: Special Flushed Inlet Manifold permits external flush for added cooling with high temperature liquids and lubrication with low lubricity liquids.

ELECTRIC HORSEPOWER REQUIREMENTS

FLOW		PRESSURE			RPM
		PSI 800	PSI 900	PSI 1000	
U.S. GPM	L/M	BAR 55	BAR 63	BAR 70	
45	170	24.7	27.8	30.9	765
40	151	22.0	24.7	27.4	680
35	133	19.2	21.6	24.0	595

**DETERMINING
THE PUMP R.P.M.**

$\frac{\text{Rated G.P.M.}}{\text{Rated R.P.M.}} = \frac{\text{"Desired" G.P.M.}}{\text{"Desired" R.P.M.}}$

**DETERMINING
THE REQUIRED H.P.**

$\frac{\text{GPM} \times \text{PSI}}{1460} = \text{Electric Brake H. P. Required}$

**DETERMINING
MOTOR PULLEY SIZE**

$\frac{\text{Motor Pulley O.D.}}{\text{Pump R.P.M.}} = \frac{\text{Pump Pulley O.D.}}{\text{Motor R.P.M.}}$

See complete Drive Packages [Inclds: Pulleys, Belts, Hubs, Key] Tech Bulletin 003. Refer to pump **Service Manual** for repair procedure, additional technical information and **pump warranty**.

"Customer confidence is our greatest asset"

PARTS LIST

ITEM	PART NUMBER		DESCRIPTION	QTY
	3841 MATL	3841K MATL		
2	34021	34021	Key (M10x8x70)	1
5	125753	125753	Screw, HH Sems (M8x25)	8
8	44542	44542	Cover, Bearing	2
9	815279	815279	Shim, Split 2-Pc	0-2
10	12398	12398	O-Ring, Bearing Cover - 70D	2
11	13296	13296	Seal, Oil, Crankshaft	2
15	29326	29326	Bearing, Roller	2
20	121467	121467	Rod, Connecting Assy (Incls: 21,22,23) [10/00]	3
21	126749	126749	Washer, Locking	3
22	126574	126574	Washer, Flat (M10)	6
23	122045	122045	Screw, HH (M10x55)	6
25	29325	29325	Crankshaft, Dual End (M48)	1
31	828710	828710	Protector, Oil Cap w/Foam Gasket	1
32	43211	43211	Cap, Oil Filler	1
33	14177	14177	O-Ring, Oil Filler Cap - 70D	1
34	126743	126743	Bolt, Eye (M12x1.75) (For Lifting Pump Only)	1
37	92241	92241	Gauge, Oil, Bubble w/Gasket - 80D	1
38	44428	44428	Gasket, Flat - 80D	1
40	125753	125753	Screw, HH Sems (M8x25)	8
48	25625	25625	Plug, Drain (1/4"x19BSP)	1
49	23170	23170	O-Ring, Drain Plug - 70D	1
50	45936	45936	Cover, Rear	1
51	16612	16612	O-Ring, Cover - 70D	1
53	44487	44487	Crankcase Assy (Incls: 34, 54)	1
55	27488	27488	Pins, Guide	2
64	43864	43864	Pin, Crosshead	3
65	45116	45116	Rod, Plunger	3
69	126587	126587	Washer, Oil Seal	3
70	100488	100488	Seal, Oil, Crankcase	3
	44739	44739	Seal, Oil, Crankcase	3
75	43865	43865	Slinger, Barrier	3
88	45676	45676	Washer, Keyhole (M16)	3
90	46806	46806	Plunger (M45x145)	3
95	89778	89778	Stud, Plunger Retainer (M10x135)	3
96	20189	20189	Back-up-Ring, Plunger Retainer	3
97	11345	11345	O-Ring, Plunger Retainer - 70D	3
	11375	11375	O-Ring, Plunger Retainer	3
	701490	701490	O-Ring, Plunger Retainer	3
98	44085	44085	Gasket, Plunger Retainer	3
99	44084	44084	Retainer, Plunger (M10)	3
100	44119	44119	Retainer, Seal	3
106	48384	48384	Seal, LPS w/SS-Spg	3
	702013	702013	Seal, LPS w/SS-Spg	3
	46945	46945	Seal, LPS w/SS-Spg	3
107	48380	48380	Spacer, LPS	3
110	701865	—	Manifold, Inlet, Block-Style	1
	—	701982	Manifold, Inlet, Block-Style, Flushed (1/2" NPTF Flush)	1
111	701116	701116	Plug, Inlet (1-1/2" NPT)	1
112	701632	701632	O-Ring, Inlet Spacer	6
	701328	701328	O-Ring, Inlet Spacer	6
	701973	701973	O-Ring, Inlet Spacer	6
113	701329	701329	Back-up-Ring, Inlet Spacer	6
114	701327	701327	Spacer, Inlet	3
117	44585	44585	Screw, HSH (M14x40)	4
118	70177	—	Plug (1/4" NPT)	3
126	48383	48383	Adapter, Female	3
127	46813	46813	V-Packing	6
	703080	703080	V-Packing	6
128	48386	48386	Adapter, Male	3
141	45113	45113	Spring, Coil	6/18
142	48382	48382	Spacer w/Coil Springs	3
155	17784	17784	O-Ring, Spacer - 80D	3
	20138	20138	O-Ring, Spacer - 80D	3
	701658	701658	O-Ring, Spacer - 80D	3
157	48381	48381	Spacer, V-Packing	3
159	17784	17784	O-Ring, Spacer - 80D	3
	20138	20138	O-Ring, Spacer - 80D	3
	701658	701658	O-Ring, Spacer - 80D	3
163	26143	26143	O-Ring, Seat	6
	14331	14331	O-Ring, Seat	6
	701660	701660	O-Ring, Seat	6
164	48393	48393	Seat	6
166	44108	44108	Valve	6
167	44109	44109	Spring	6
168	44728	44728	Retainer, Spring	6
170	44729	44729	Washer, Spring Retainer	6
171	44644	44644	Spring, Coil (70kg), Valve Plug	6
172	89827	89827	O-Ring, Valve Plug - 90D	6
	11747	11747	O-Ring, Valve Plug - 90D	6
	701494	701494	O-Ring, Valve Plug - 70D	6
173	48364	48364	Back-up-Ring, Valve Plug	6
174	701278	701278	Plug, Valve	6
176	701316	701316	Cover, Valve	2
177	87951	87951	Screw, HSH (M10x30)	32
185	701866	701866	Manifold, Discharge, Block-Style	1
188	701279	701279	Screw, HSH (M12x100)	8
196	701342	701342	Plug, Discharge (1" NPT) Not Shown	1

Replace as a set

EXPLODED VIEW

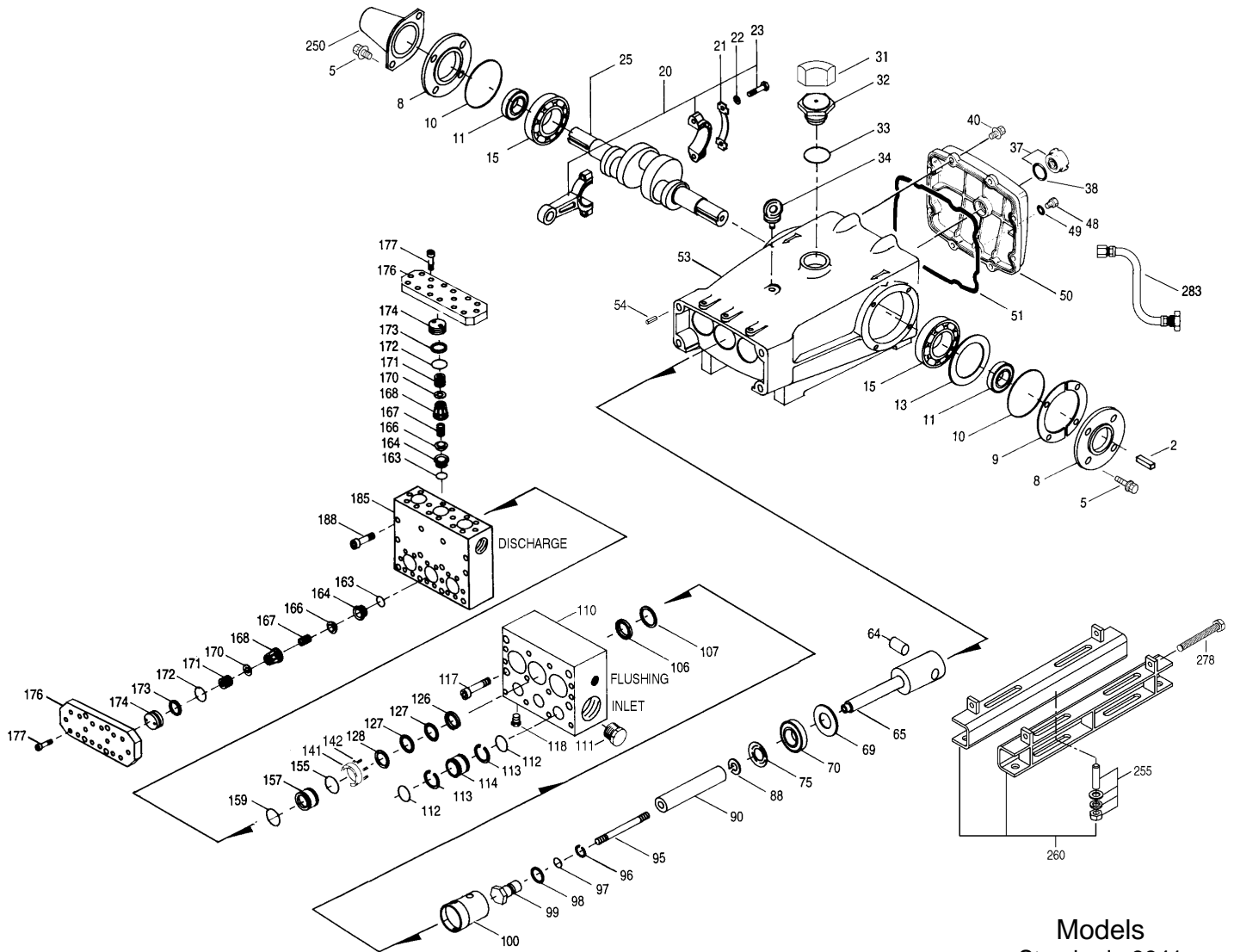

Models
 Standard - 3841
 Flushed - 3841K
 February 2009

	3841	MATL	3841K	MATL		
250	44516	NY	44516	NY	Protector, Shaft w/2 Screws, Lockwashers and Washers (Included with Pump)	1
255	34039	S	34039	S	Assy, Direct Mount	1
260	92674	STZP	92674	STZP	Mount, Rail Assy (Incls: 34018)	1
275	990013	STL	990013	STL	Hub, "B" (35mm w/keyway) [See Drive Packages Tech Bulletin 003]	1
278	80540	ZP	80540	ZP	Screw, HH (M12x100) (Rail Adjusting Screw)	1
283	34314	—	34314	—	Kit, Oil Drain (3/8" x 48")	1
290	6124	—	6124	—	Gasket, Liquid (3 oz.)	1
299	901410	SSL	—	—	Head, Complete, Block-Style	1
300	—	—	901411	SSL	Head, Complete, Block-Style, Flushed	1
	31934	NBR*	31934	NBR*	Kit, Seal (Incls: 97, 106, 112, 113, 127, 155, 159)	1
	31961	FPM*	31961	FPM*	Kit, Seal (Incls: 97, 106, 112, 113, 127, 155, 159)	1
	◆ 31923	EPDM*	◆ 31923	EPDM*	Kit, Seal (Incls: 97, 106, 112, 113, 127, 155, 159)	1
310	33835	NBR	33835	NBR	Kit, Valve, Preamsembled (Incls: 163, 164, 166, 167, 168, 170, 172, 173)	2
	31262	FPM	31262	FPM	Kit, Valve (Incls: 163, 164, 166, 167, 168, 170, 172, 173)	2
	◆ 31264	EPDM	◆ 31264	EPDM	Kit, Valve (Incls: 163, 164, 166, 167, 168, 170, 172, 173)	2
—	819000	F	819000	F	Assembly, Crankcase, Cast Iron Conversion	1
370	—	—	990663	—	Assembly, Flushing, 5 gal., 115V, 1.1 Amp, 1/2" NPT	1
390	714500	SS	714500	SS	C.A.T. (Inlet pressure stabilizer for RO and boosted applications)	1
391	714506	SS	714506	SS	Adapter (2 per C.A.T.) (See Data Sheet for complete selection)	2
392	701828	SS	701828	SS	Elbow Assy used with Adapter Assy 714506	1
—	6100	—	6100	—	Oil, Case (12-21 oz. Bottles) ISO-68 Hydraulic (Fill to specified crankcase capacity prior to start-up)	1

Bold print part numbers are unique to a particular pump model. *Italics are optional items.* [] Date of latest production change. ◆ Silicone oil/grease required.

R Components comply with RoHS Directive. * Review individual parts in each kit for material code identification.

See Tech Bulletins 002, 003, 024, 035, 036, 041, 043, 053, 074, 077, 083, 095 and 105 for additional information. **C.A.T. highly recommended for pressurized inlet, R.O. and industrial applications.**

MATERIAL CODES (Not Part of Part Number): ABS=ABS Plastic AL=Aluminum CC=Ceramic CM=Chrome-Moly D=Acetal EPDM=Ethylene Propylene Diene Monomer F=Cast Iron FBR=Fiber

FCM=Forged Chrome-moly FPM=Fluorocarbon NBR=Medium Nitrile (Buna-N) NBRs=Buna, Silicone Free NY=Nylon PPG=Glass Filled Polypropylene PTFE=Pure Polytetrafluoroethylene

PVDF=Polyvinylidene Fluoride S=304SS SFTB=Special Blend PTFE Black SSL=316SS/Low Carbon SSZZ=316SS/Zamak STG=Special Blend PTFE White STL=Steel

STZP=Steel/Zinc Plated TNM=Special High Strength ZP=Zinc Plated

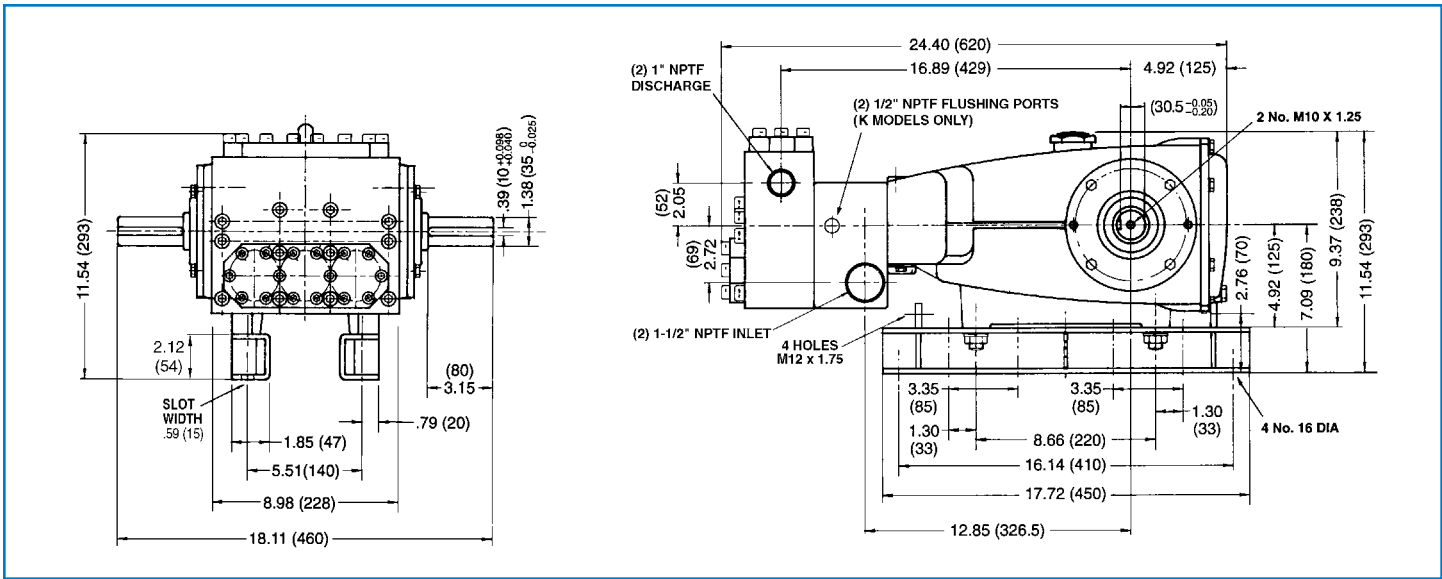

Models 3841, 3841K

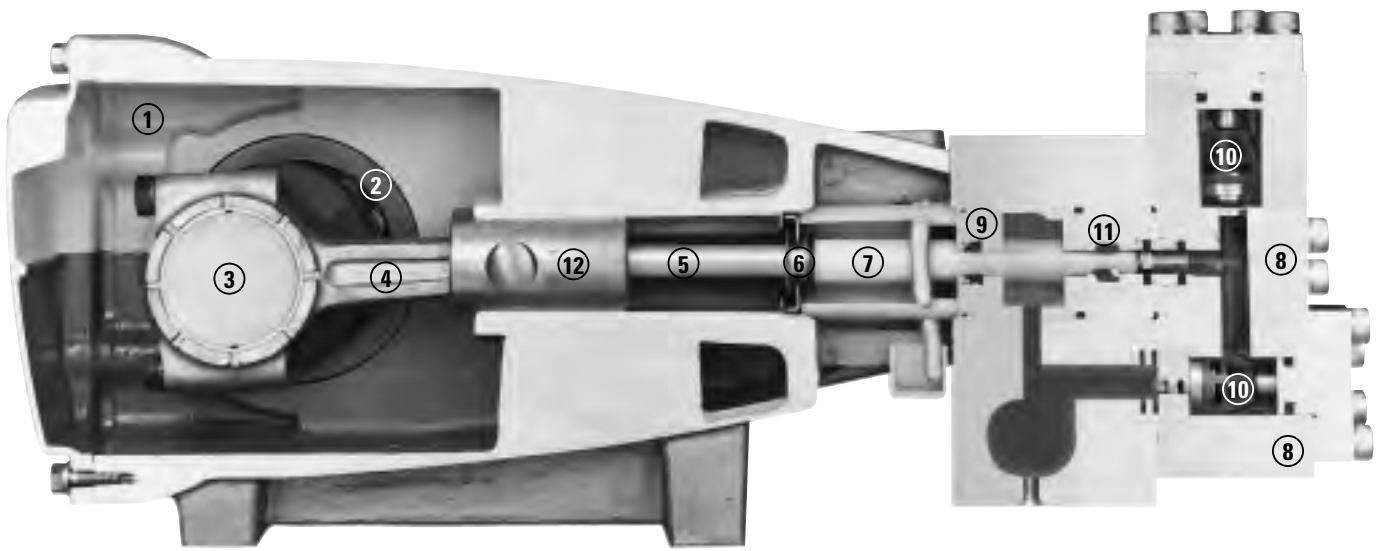

- 1 Die cast aluminum **crankcase** means high strength, lightweight, and excellent tolerance control.
- 2 Oversized crankshaft **bearings** provide extended bearing life and pump performance.
- 3 Chrome-moly **crankshaft** provides unmatched strength and surface hardness for long life.
- 4 Matched oversized high strength TNM **connecting rods** noted for superior strength and bearing quality.
- 5 Special stainless steel **plunger rods** with high strength crossheads for longevity and corrosion resistance.
- 6 The stainless steel **slinger** provides backup protection for the crankcase seal, keeping pumped liquids out of the crankcase.
- 7 Special concentric, high-density, polished, solid ceramic **plungers** provide a true wear surface and extended seal life.
- 8 **Manifolds** are 316 SSL block-style for long-term continuous-duty and corrosion resistance.
- 9 **Standard Models:** Lo Pressure Seals and V-Packings are completely lubricated and cooled by the liquid being pumped.
- 9 Special **Flushed Inlet Manifold** permits external flush for added cooling with high temperature liquids and lubrication with low lubricity liquids.
- 10 Stainless steel **valves, seats and springs** provide corrosion-resistance, ultimate seating and extended life.
- 11 Specially formulated, CAT PUMP exclusive, **V-Packings** offer unmatched performance and seal life.
- 12 **Crossheads** are 360° supported for uncompromising alignment.

World Headquarters
CAT PUMPS
 1681 - 94th Lane N.E. Minneapolis, MN 55449-4324
 Phone (763) 780-5440 — FAX (763) 780-2958
 e-mail: techsupport@catpumps.com
 www.catpumps.com

International Inquiries
 FAX (763) 785-4329
 e-mail: intlsales@catpumps.com



CAT PUMPS (U.K.) LTD.
 1 Fleet Business Park, Sandy Lane, Church Crookham
 FLEET, Hampshire, GU52 8BF, England
 Phone Fleet 44 1252-622031 — Fax 44 1252-626655
 e-mail: sales@catpumps.co.uk www.catpumps.co.uk

N.V. CAT PUMPS INTERNATIONAL S.A.
 Heiveldekens 6A, B-2550 Kontich, Belgium
 Phone 32-3-450.71.50 — Fax 32-3-450.71.51
 e-mail: cpi@catpumps.be www.catpumps.be

CAT PUMPS DEUTSCHLAND GmbH
 Buchwiese 2, D-65510 Idstein, Germany
 Phone 49 6126-9303 0 — Fax 49 6126-9303 33
 e-mail: catpumps@t-online.de www.catpumps.de