

Motorized pump unit 2SF42SEEL251 Shown

Stainless Steel Direct-Drive Plunger Pump

**Models 2SF05SEEL, 2SF10SEEL
2SF15SEEL, 2SF22SEEL
2SF25SEEL, 2SF29SEEL
2SF35SEEL, 2SF42SEEL**

FEATURES

- Rugged 316SS design engineered for SWRO high duty cycles.
- High efficiency triplex design with unique spring loaded inlet valves and flow through plungers for smooth low pulsation flow.
- 56C direct-drive 50/60 Hz motor satisfies international power requirements.
- Compact motor-pump units provide the smallest possible footprint for challenging spaces.

COMMON SPECIFICATIONS

Discharge Pressure Range.....	100-1200 psi	(7-85 bar)
Inlet Pressure Range.....	Flooded to 60 psi	(Flooded to 4 bar)
Shaft Diameter	5/8"	(15.9 mm)
RPM.....	1725 rpm	(1725 rpm)
Bore.....	0.709"	(18 mm)
Bore (2SF42SEEL Only)	0.787"	(20 mm)
Maximum Liquid Temperature	160°F	(70°C)
Above 130°F call CAT PUMPS for inlet conditions and elastomer recommendations.		
Crankcase Capacity	11.15 oz.	(0.33 l)
Inlet Port (1)	3/8" NPTF	(3/8" NPTF)
Discharge Ports (2).....	3/8" NPTF	(3/8" NPTF)
By-Pass Return Port (1)	1/4" NPTF	(1/4" NPTF)
Weight (Pump Only)	8.9 lbs.	(4 kg)
Dimensions (Pump Only).....	6.8 x 8.7 x 5.2"	(173 x 221 x 133 mm)

⚠ CAUTIONS AND WARNINGS

All High Pressure Systems require a primary pressure regulating device (i.e. regulator, unloader) and a secondary pressure relief device (i.e. pop-off valve, relief valve). Failure to install such relief devices could result in personal injury or damage to pump or property. CAT PUMPS does not assume any liability or responsibility for the operation of a customer's high pressure system.

Read all CAUTIONS and WARNINGS before commencing service or operation of any high pressure system. The CAUTIONS and WARNINGS are included in each service manual and with each Accessory Data sheet. CAUTIONS and WARNINGS can also be viewed online at www.catpumps.com/cautions-warnings or can be requested directly from CAT PUMPS.

WARRANTY

View the Limited Warranty on-line at www.catpumps.com/warranty.

SPECIFICATIONS

U.S. Measure

Metric Measure

MODEL 2SF05SEEL

Flow (60 Hz-1725 rpm).....	0.5 gpm	(1.9 l/m)
Flow (50 Hz-1450 rpm).....	0.42 gpm	(1.6 l/m)
Stroke	0.071"	(1.8 mm)

MODEL 2SF10SEEL

Flow (60 Hz-1725 rpm).....	1.0 gpm	(3.8 l/m)
Flow (50 Hz-1450 rpm).....	0.84 gpm	(3.1 l/m)
Stroke	0.122"	(3.1 mm)

MODEL 2SF15SEEL

Flow (60 Hz-1725 rpm).....	1.5 gpm	(5.7 l/m)
Flow (50 Hz-1450 rpm).....	1.26 gpm	(4.8 l/m)
Stroke	0.177"	(4.5 mm)

MODEL 2SF22SEEL

Flow (60 Hz-1725 rpm).....	2.2 gpm	(8.3 l/m)
Flow (50 Hz-1450 rpm).....	1.84 gpm	(7.0 l/m)
Stroke	0.248"	(6.3 mm)

MODEL 2SF25SEEL

Flow (60 Hz-1725 rpm).....	2.5 gpm	(9.5 l/m)
Flow (50 Hz-1450 rpm).....	2.1 gpm	(7.9 l/m)
Stroke	0.287"	(7.3 mm)

MODEL 2SF29SEEL

Flow (60 Hz-1725 rpm).....	2.85 gpm	(10.8 l/m)
Flow (50 Hz-1450 rpm).....	2.4gpm	(9.1 l/m)
Stroke	0.335"	(8.5 mm)

MODEL 2SF35SEEL

Flow (60 Hz-1725 rpm).....	3.5 gpm	(13.2 l/m)
Flow (50 Hz-1450 rpm).....	2.9 gpm	(11.0 l/m)
Stroke	0.402"	(10.2 mm)

MODEL 2SF42SEEL

Flow (60 Hz-1725 rpm).....	4.2 gpm	(15.9 l/m)
Flow (50 Hz-1450 rpm).....	3.5 gpm	(13.2 l/m)
Discharge Pressure Range.....	100-1000 psi	(7-70 bar)
Stroke	0.402"	(10.2 mm)

Refer to pump **Service Manual** for repair procedure and additional technical information.

PARTS LIST

ITEM	P/N	MATL	DESCRIPTION	MODEL USED	QTY	ITEM	P/N	MATL	DESCRIPTION	MODEL USED	QTY	
5	547445	S	Screw, HHC Sems (M6x14) [3/03]	All	3	152	† 26089	NBR	O-Ring, Adapter Spacer, Inner-80D	05-35SEEL	3	
8	547153	AL	Cover, Bearing [3/03]	All	1		11377	FPM	O-Ring, Adapter Spacer, Inner-80D	05-35SEEL	3	
10	14041	NBR	O-Ring, Bearing Cover-70D [3/03]	All	1		46647	EPDM	O-Ring, Adapter Spacer, Inner-80D	05-35SEEL	3	
11	55337	NBR	Seal, Oil, Crankshaft -70D [3/03]	All	1		549539	NBR	O-Ring, Adapter Spacer, Inner	42SEEL	3	
15	14488	STL	Bearing, Ball - Inner	All	1		129977	FPM	O-Ring, Adapter Spacer, Inner	42SEEL	3	
20	547046	TNM	Rod, Connecting	All	3		129978	EPDM	O-Ring, Adapter Spacer, Inner	42SEEL	3	
25	831987	CM	Crankshaft, 1.8mm	05SEEL	1	157	544700	SS	Adapter, Valve	05-35SEEL	3	
	46109	CM	Crankshaft, 3.1mm	10SEEL	1		831289	SS	Adapter, Valve	42SEEL	3	
	44931	CM	Crankshaft, 4.5mm	15SEEL	1	159	† 26089	NBR	O-Ring, Adapter Spacer, Outer-80D	All	3	
	45160	CM	Crankshaft, 6.3mm	22SEEL	1		11377	FPM	O-Ring, Adapter Spacer, Outer-80D	All	3	
	544693	CM	Crankshaft, 7.3mm	25SEEL	1		46647	EPDM	O-Ring, Adapter Spacer, Outer-80D	All	3	
	45914	CM	Crankshaft, 8.5mm	29SEEL	1	164	544293	SS	Seat	All	3	
	544694	CM	Crankshaft, 10.2mm	35SEEL, 42SEEL	1	166	543669	SS	Valve	All	3	
26	12385	STL	Ring, Retaining, Bearing	All	1	167	543700	SS	Spring	All	3	
27	15710	STL	Bearing, Ball - Outer	All	1	168	44565	PVDF	Retainer, Spring	All	3	
31	549726	—	Cap, Vented w/O-Ring (Rain Cap)	All	1	185	547705	SS	Manifold, Discharge	All	1	
32	547961	RTP	Cap, Oil Filler w/O-Ring	All	1	188	544701	S	Screw, HSH (M8x80)	All	6	
33	14179	NBR	O-Ring, Oil Filler Cap - 70D	All	2	255	30517	STZP R	Assy, Bolt Mount	All	1	
37	92241	—	Gauge, Oil w/Gasket - 80D	All	1	283	990394	—	Kit, Oil Drain	All	1	
38	44428	NBR	Gasket, Flat, Oil Gauge - 80D	All	1	285	80228	STL	Screw (M8-1.25x80) (Motor Removal) (Not Shown)	All	2	
48	44842	NY	Plug, Drain	All	1	300	34973	NBR	Kit, Seal (Incls: 106, 125, 152, 159)	05-35SEEL	1	
49	14179	NBR	O-Ring, Drain Plug - 70D	All	1		33453	FPM	Kit, Seal (Incls: 106, 125, 152, 159)	05-35SEEL	1	
53	547285	AL	Crankcase (See Tech Bulletin 92)	All	1		30536	EPDM	Kit, Seal (Incls: 106, 125, 152, 159)	05-35SEEL	1	
64	16948	CM	Pin, Crosshead	All	3		76973	NBR	Kit, Seal (Incls: 106, 125, 152, 159)	42SEEL	1	
65	544695	SSZZ	Rod, Plunger	All	3		76955	FPM	Kit, Seal (Incls: 106, 125, 152, 159)	42SEEL	1	
69	126259	STCP R	Washer, Oil Seal	All	3		76996	EPDM	Kit, Seal (Incls: 106, 125, 152, 159)	42SEEL	1	
70	25461	NBR	Seal, Oil Crankcase	All	3	310	34972	NBR	Kit, Valve (Incls: 152,159,164,166,167,168)	05-35SEEL	1	
90	544697	CC	Plunger, Ceramic (M18x18)	05-35SEEL	3		33454	FPM	Kit, Valve (Incls: 152,159,164,166,167,168)	05-35SEEL	1	
	831290	CC	Plunger, Ceramic (M20x18)	42SEEL	3		30546	EPDM	Kit, Valve (Incls: 152,159,164,166,167,168)	05-35SEEL	1	
100	44869	PVDF	Retainer, Seal	All	3		76972	NBR	Kit, Valve (Incls: 152,159,164,166,167,168)	42SEEL	1	
106	547683	NBR	Seal, LPS w/SS-Spg	All	3		76445	FPM	Kit, Valve (Incls: 152,159,164,166,167,168)	42SEEL	1	
	545192	FPM	Seal, LPS w/SS-Spg	All	3		76446	EPDM	Kit, Valve (Incls: 152,159,164,166,167,168)	42SEEL	1	
	546507	EPDM	Seal, LPS w/SS-Spg	All	3		311	39668	NBR	Kit, Inlet Valve w/SS-IV (Incls:134-138,152,159)	05-35SEEL	1
110	547704	SS	Manifold, Inlet	05-35SEEL	1		34974	NBR	Kit, Inlet Valve w/NY-IV (Incls:134-138,152,159)	05-35SEEL	1	
	831288	SS	Manifold, Inlet	42SEEL	1		33460	FPM	Kit, Inlet Valve w/NY-IV (Incls:134-138,152,159)	05-35SEEL	1	
125	44652	SNG	Seal, HPS w/SS	05-35SEEL	3		30556	EPDM	Kit, Inlet Valve w/NY-IV (Incls:134-138,152,159)	05-35SEEL	1	
	46652	HT*	Seal, Hi-Temp, 2-Pc w/S-Support	05-35SEEL	3		76668	NBR	Kit, Inlet Valve w/SS-IV (Incls:134-138,152,159)	42SEEL	1	
	44649	SNG	Seal, HPS w/SS	42SEEL	3		76465	FPM	Kit, Inlet Valve w/SS-IV (Incls:134-138,152,159)	42SEEL	1	
	44936	FPM	Seal, HPS w/SS	42SEEL	3		76466	EPDM	Kit, Inlet Valve w/SS-IV (Incls:134-138,152,159)	42SEEL	1	
	46667	HT*	Seal, Hi-Temp, 2-Pc w/S-Support	42SEEL	3	352	44050	STPZ	Tool, Oil Gauge Removal	All	1	
134	543691	SS	Valve, Inlet (See Tech Bulletin 91)	05-35SEEL	3	—	6107	—	Oil, Bottle (21 oz) ISO-68 Hydraulic (Fill to specified crankcase capacity prior to start-up)	All	1	
	33873	NY	Valve, Inlet (See Tech Bulletin 91)	05-35SEEL	3	—	6575	—	Plunger Pump Service DVD	All	1	
	831400	SS	Valve, Inlet	42SEEL	3	—	6119	—	Lubricant, Antiseize (1 oz.)	All	1	
135	543689	SS	Spacer	All	3							
136	543690	SS	Spring, Inlet Valve	All	3							
137	88575	S	Washer, Conical (M6)	All	3							
138	543692	SS	Nut (M6)	All								

Bold print part numbers are unique to a particular pump model. Italics are optional items.

[] Date of latest production change. † Production parts are different than repair parts. R Components comply with RoHS Directive.

*Review individual parts in each kit for material code identification.

View Tech Bulletins 002, 036, 043, 055, 064, 070, 073, 074, 091, 092 and 095 for additional information.

NOTE: Discard Key that may come standard with most motors and engines and use only the key included in Bolt kit.

MATERIAL CODES (Not Part of Part Number): AL=Aluminum CC=Ceramic CM=Chrome-Moly

EPDM=Ethylene propylene diene monomer FPM=Fluorocarbon HT=Hi-Temp (EPDM Alternative) NBR=Medium Nitrile (Buna-N) NY=Nylon

PVDF=Polyvinylidene Fluoride RTP=Reinforced Composite S=304SS SNG=Special Blend (Buna) SS=316SS SSZZ=316SS Zamak

STL=Steel STCP=Steel/Chrome Plated STZP=Steel/Zinc Plated TNM=Special High Strength

EXPLODED VIEW November 2012

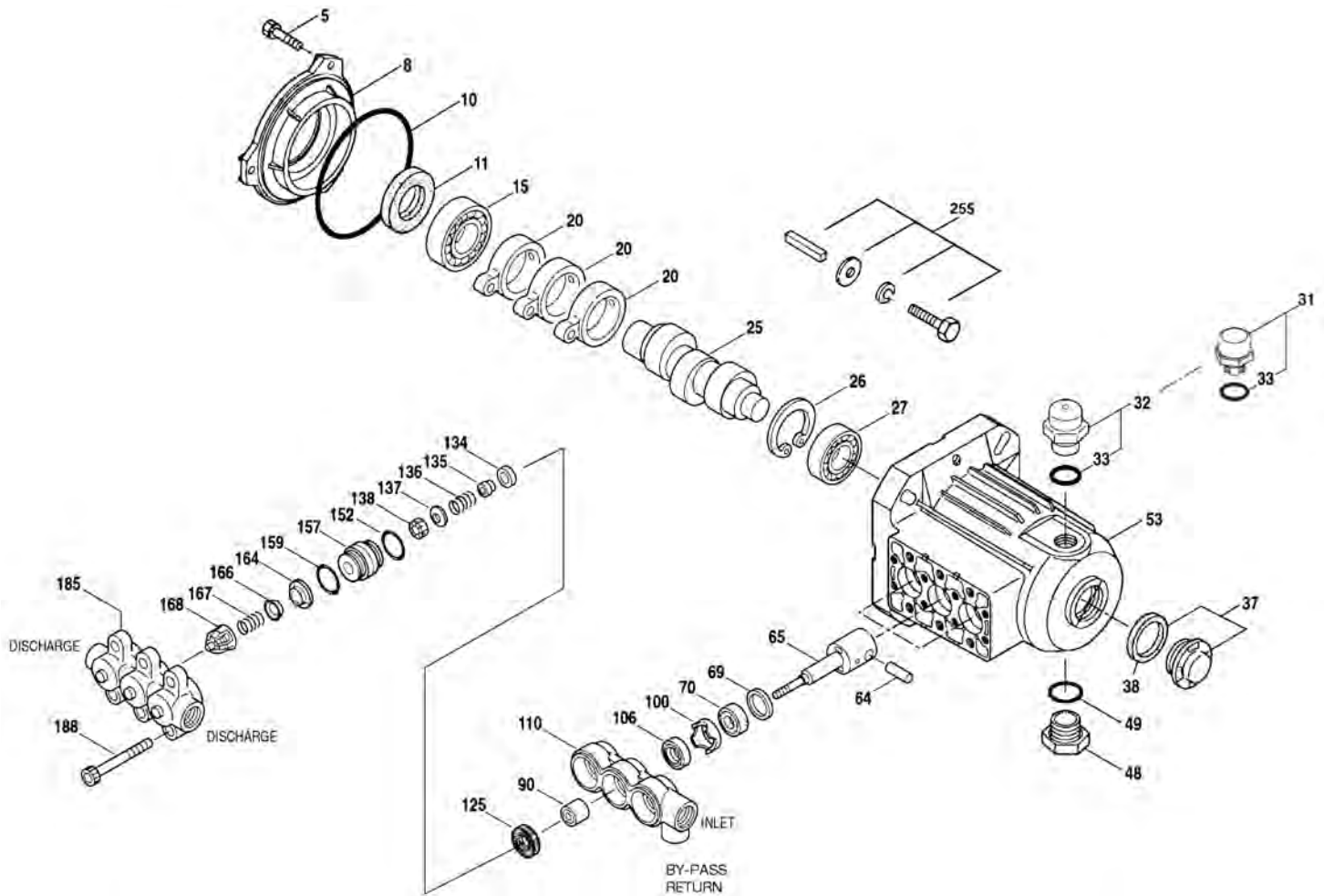

MOTOR SPECIFICATIONS							
MODEL	8105	8175	8110	8060	8062	8082	8125
HorsePower	0.5	0.75	1.0	1.5	2.0	2.0/1.5	2.5
Phase	Single	Single	Single	Single	Single	Three	Single
RPM	1750	1745	1750	1725	1725	1725/1425	1750/1450
Frame Size	56C TEFC	56C TEFC	56C TEFC	56C TEFC	56C TEFC	56HC TEFC	56HC TEFC
Shaft Diameter (inches)	5/8	5/8	5/8	5/8	5/8	5/8	5/8
Maximum Volts	115/208-230	115/208-230	115/208-230	115/230	115/230	208-230/460 190/380	115/230 110/220
FULL LOAD AMPS	7.4/3.6-3.7	10.6/5.2-5.3	14/6.8-7.0	14.0/7.0	17.0/8.5	5.9-5.6/2.8 5.2/2.6	21/11.5 23.6/11.8
Hertz	60	60	60	60	60	60/50	60/50
Service Factor	1.15	1.15	1.15	1.2	1.15	1.15	1.2/1.0
Max. Ambient Temp. (°F)	104	104	104	104	104	104	104
Capacitor Start	Yes	Yes	Yes	Yes	Yes	No	Yes
Thermal Overload-Manual Reset	No	Yes	No	Yes	Yes	No	No
Weight (lbs.)	25	28	34	42	45.7	40	52.9

NOTE: Motor start-up AMPS may vary, then settle within FULL LOAD AMPS rating after initial run time.

ELECTRIC HORSEPOWER REQUIREMENTS					
FLOW		PRESSURE psi (bar)			PUMP rpm
U.S. gpm	Metric l/m	700 (50)	1000 (70)	1200 (85)	
0.5	1.9	0.24	0.35	0.41	1725
1.0	3.8	0.47	0.68	0.82	1725
1.5	5.7	0.72	1.03	1.23	1725
2.5	9.5	1.19	1.71	2.05	1725
2.85	10.8	1.36	2.0	2.3	1725
3.5	13.2	1.67	2.39	2.87	1725
4.2	15.9	2.01	2.88	N/A	1725

DETERMINING REQUIRED H.P.

$$\frac{\text{gpm} \times \text{psi}}{1460} = \text{Electric Brake H.P. Required}$$

★ ★ Before mounting pump on motor, apply P.N. 6106 Antiseize Lubricant to pump shaft.

Refer to Tech Bulletin 055 for instructions on removing pump from electric motor.

For warranty consideration contact CAT PUMPS for the local Authorized Service Center. If you are uncertain as to the cause of failure (Pump or Motor), secure **Returned Goods Authorization number** and return complete assembly **PREPAID** to CAT PUMPS for evaluation.

MODEL	8105	8175	8110	8060	8062	8082	8125
Dimension A	15.9	15.9	17.1	18.7	19.2	18.0	19.0
Dimension B	9.0	9.0	10.2	11.8	12.3	11.2	12.2
Dimension C	8.2	8.2	8.2	8.1	8.1	6.9	9.6
Dimension D	9.1	9.1	9.1	9.5	9.5	9.5	9.7

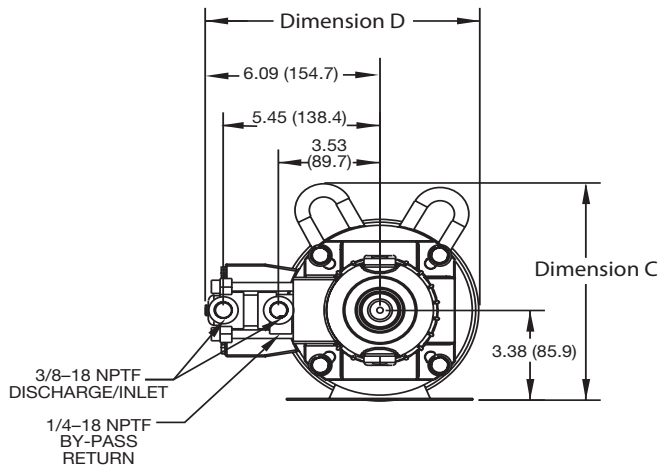
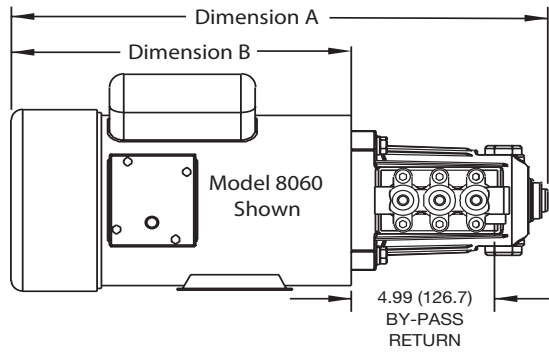

Models 2SF05SEEL, 2SF10SEEL, 2SF15SEEL, 2SF25SEEL, 2SF29SEEL, 2SF35SEEL, 2SF42SEEL

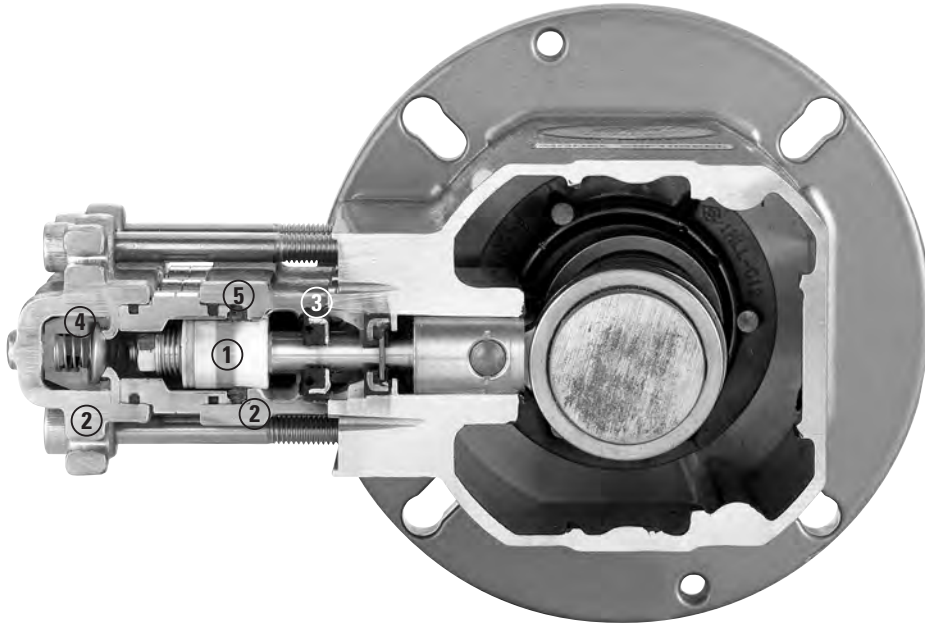

- 1 Special concentric, high-density, polished, solid ceramic **plungers** provide a true wear surface and extended seal life.
- 2 **Manifolds** are 316 stainless steel for long term continuous duty and corrosion resistance.
- 3 100% wet **seal** design adds to service life by allowing pumped liquids to cool and lubricate on both sides.
- 4 Stainless steel **valves, seats and springs** provide corrosion-resistance, positive seating and long life.
- 5 Unique design and specially formulated **Hi-Pressure Seals** offer unmatched performance and seal life.



CAT PUMPS
 1681 - 94TH LANE N.E. MINNEAPOLIS, MN 55449-4324
 PHONE (763) 780-5440 — FAX (763) 780-2958
 e-mail: techsupport@catpumps.com
 www.catpumps.com