

SECTION	7
PAGE	3
ISSUED	2/03
REPLACES	12/01

PEDESTAL SUMP PUMP

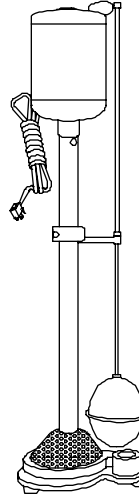

FEATURES

Brass column, strainer and float rod.

Stainless steel shaft. Copper float ball.

Volute, impeller and base are corrosion resistant red bronze.

Powered for continuous operation with a 1/3 Hp., 115 Volt, single phase, 60Hz motor with built-in overload protection, 8 foot heavy duty 3-wire cord.

Float operated switch built-in motor.

60Hz - PERFORMANCE - 1750RPM							
Catalog Number	Ship. Weight lbs. (kg)	Disch. Size Inches	Total Head in Feet (Meters)				
			5 (1.5)	10 (3.0)	15 (4.5)	20 (6.0)	23 (7.0)
Capacity in G.P.M. (L.P.S.)							
3FC2	32 (14.5)	1 ¹ / ₄	55 (3.46)	47 (2.96)	38 (2.39)	27.5 (1.73)	16.6 (1.04)

SECTION	7
PAGE	4
ISSUED	2/03
REPLACES	12/01



420 Third Street
Piqua, Ohio 45356-0603
Phone: (937) 778-8947 Fax: (937) 773-7157

PEDESTAL SUMP PUMP

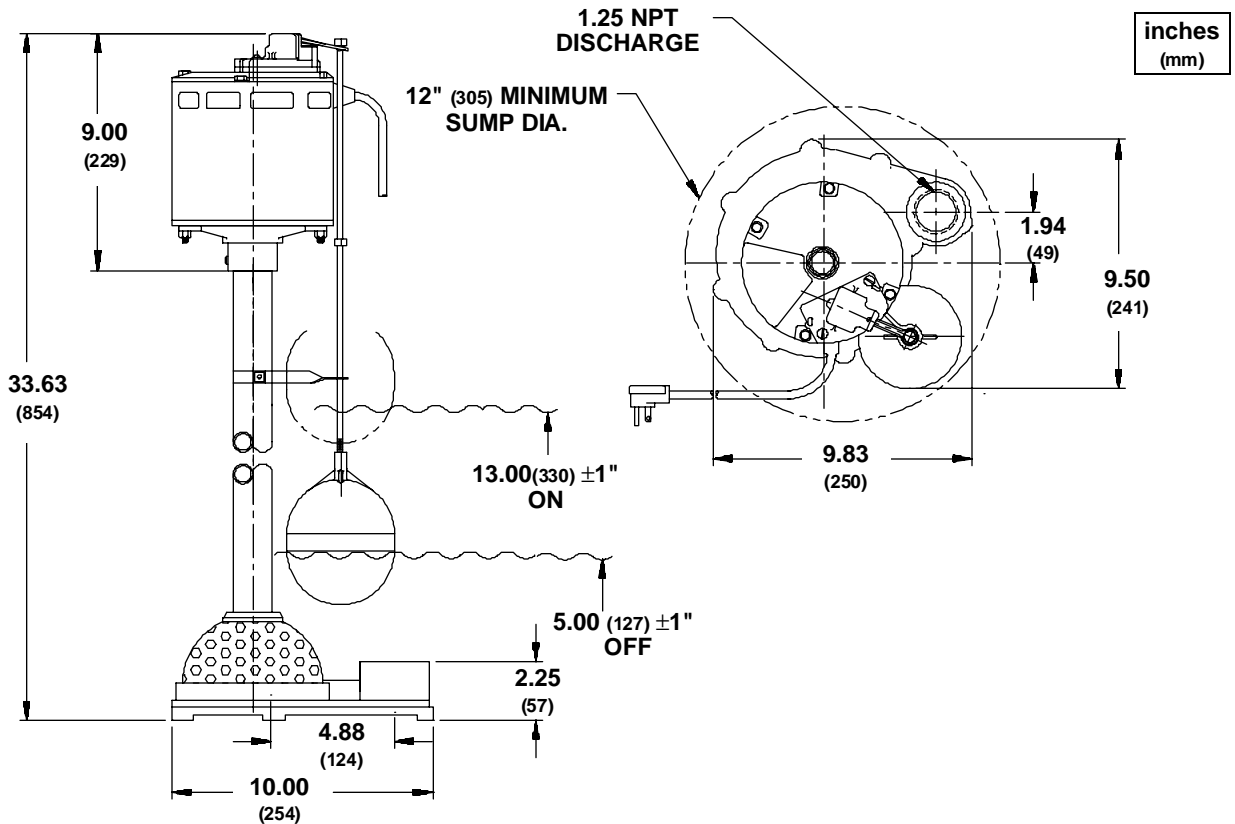
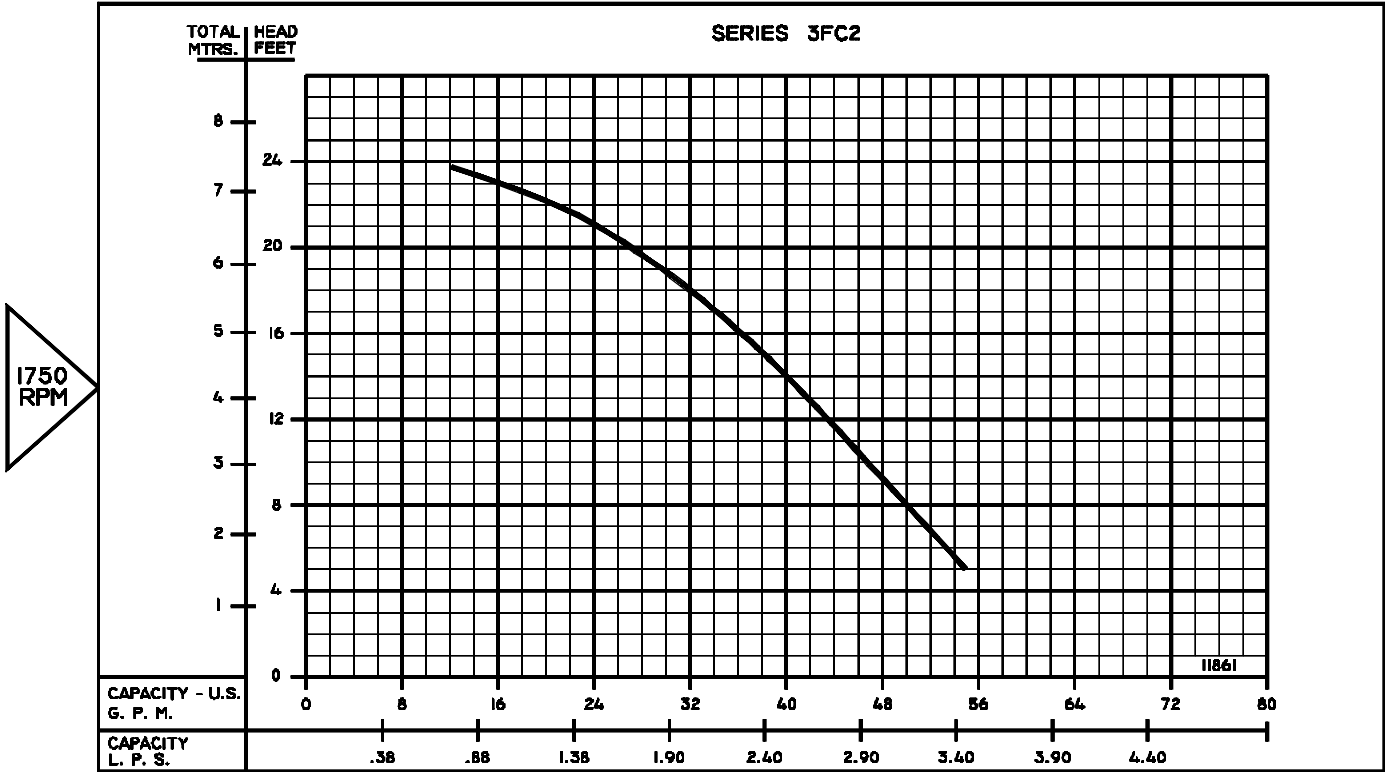

PUMPS & SYSTEMS

A Crane Co. Company