

Ampco Pumps Company



Ampco ZP3 Series (Addendum)

- Positive Displacement Pumps
 - Installation and Maintenance Manual



Pump Disassembly

1) Start by removing the cover nuts with an appropriate wrench (Figure 1). During disassembly place all parts on a clean, protected surface with finished surfaces and seal faces facing up. Tap the cover off using a soft mallet. Remove the cover o-ring and inspect it.

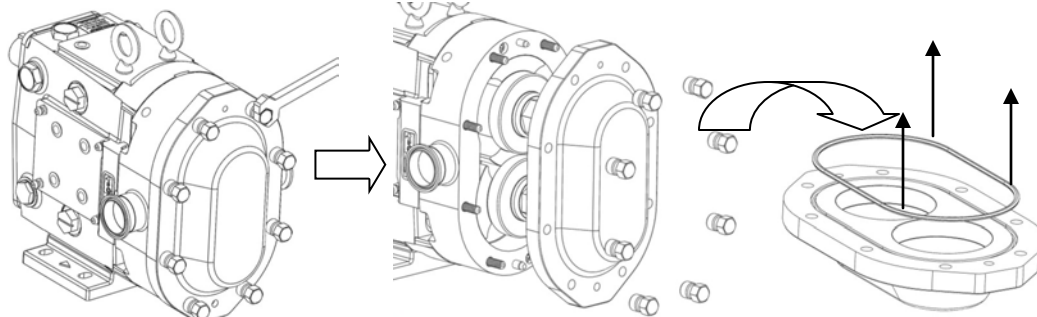

Figure 1: Removing ZP3 Cover

2) Loosen each rotor nut using the appropriate size wrench and a non-metallic wedge to keep the rotors from moving (Figure 2). Unthread each nut and disassembly the nut assembly (Rotor nut, Bellville washer and retaining o-ring).

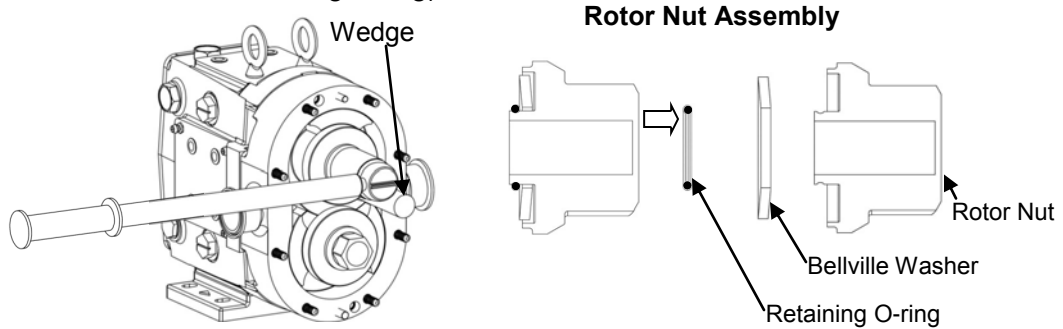
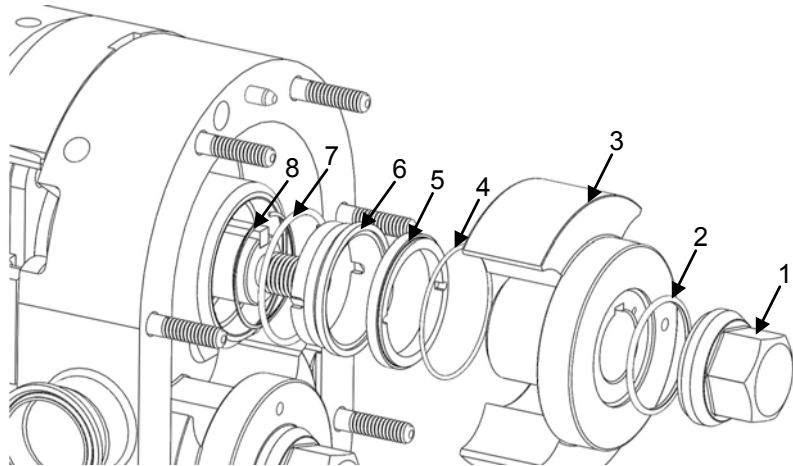

Figure 2: Rotor Removal

3) Remove the rotors by orientating them perpendicular to each other and then pulling them out. It is important to be cautious with the rotors so that they are not damaged in any way. If rotors are difficult to remove, use a nylon or wood lever to pry them out without damaging the body or the rotors. Use Figure 3 to ensure that all parts are removed.



	Part
1	Rotor Nut Assembly
2	Rotor Nut O-ring
3	ZP3 Rotor
4	Rotating Seal O-ring
5	Rotating Seal
6	Stationary Seal
7	Stationary Seal O-ring
8	Wave Spring

Figure 3: Exploded View

Seal Assembly

1) Start by inserting the wave spring into the sleeve making sure that it sets below the stationary drive pins (Figure 4). Insert a rotor key in the keyway on the shaft.

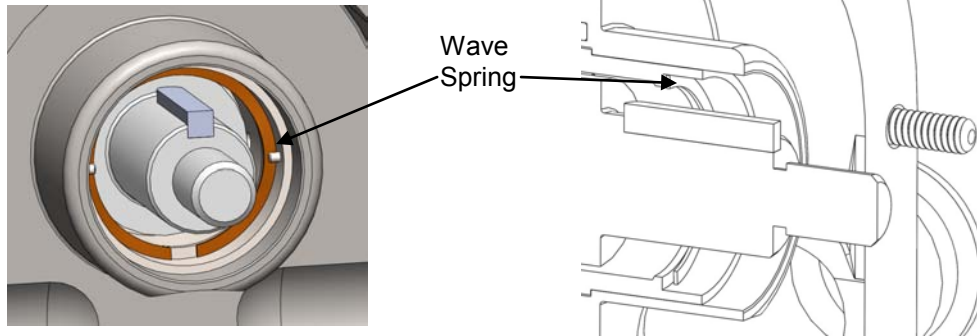

Figure 4: Inserting Spring

2) Slide the stationary seal o-ring into the body hub until it seats against the top of the sleeve (previously installed). Align the slots on the stationary seal with the pins inside the hub. Press the stationary seal into the hub until it seats on the spring; there should be noticeable spring resistance when pushing on the seal.

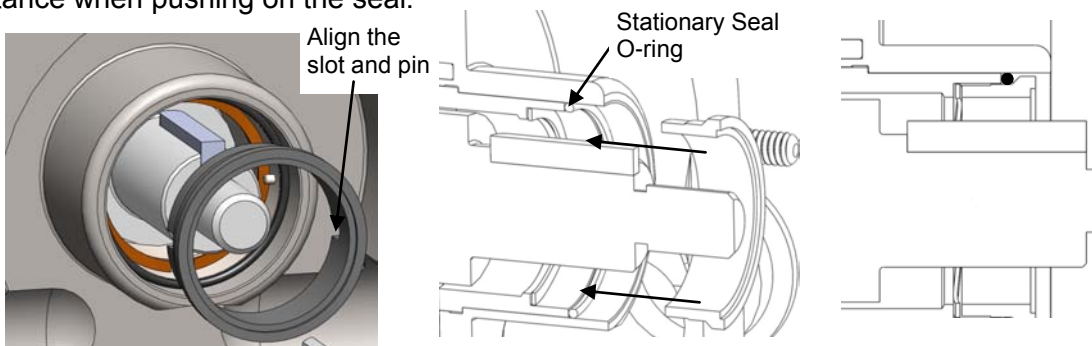

Figure 5: Stationary Seal Assembly

3) Next install the rotating o-ring onto the rotating seal by stretching it (not rolling) onto the rotating seal (Figure 6).

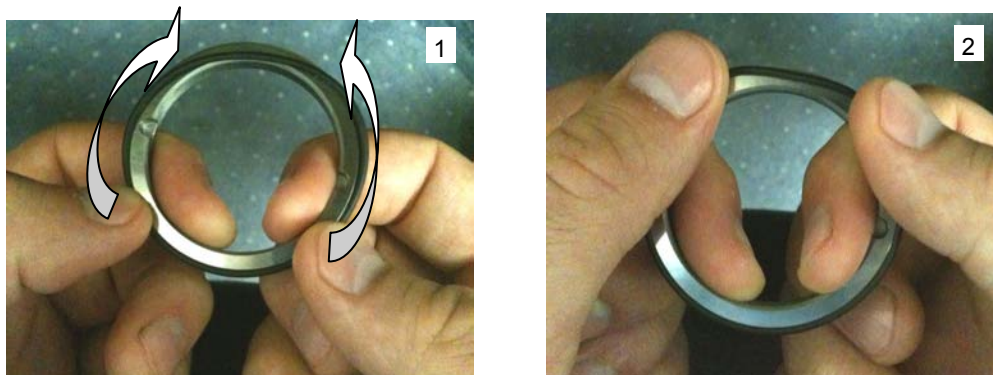

Figure 6: Installing the Rotating O-ring

Pump Assembly

4) Slide the rotating seal onto the rotor hub (Figure 7) making sure to align the slots on the seal to the drive pins in the rotor. Press the seal down until it seats inside of the rotor.

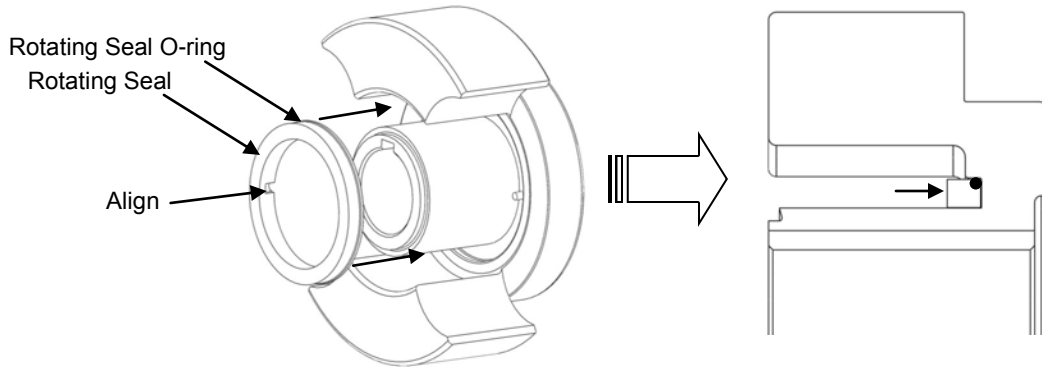

Figure 7: Inserting Rotating O-ring

5) Slide the rotors on to the shafts until they seat against the shaft shoulder (Figure 8).

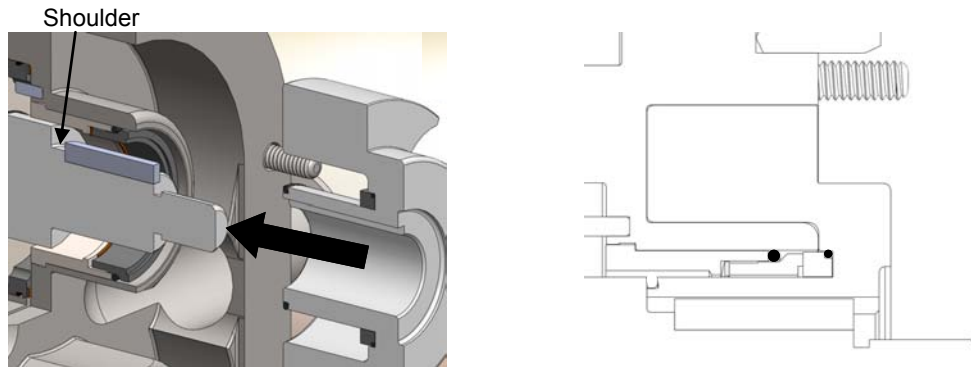

Figure 8: Rotor Assembly

6) Install the Bellville washers in the rotor nuts in the orientation shown and hold them in place using the small retaining o-rings (Figure 9). Install a rotor nut o-ring before threading the nut onto the shaft.

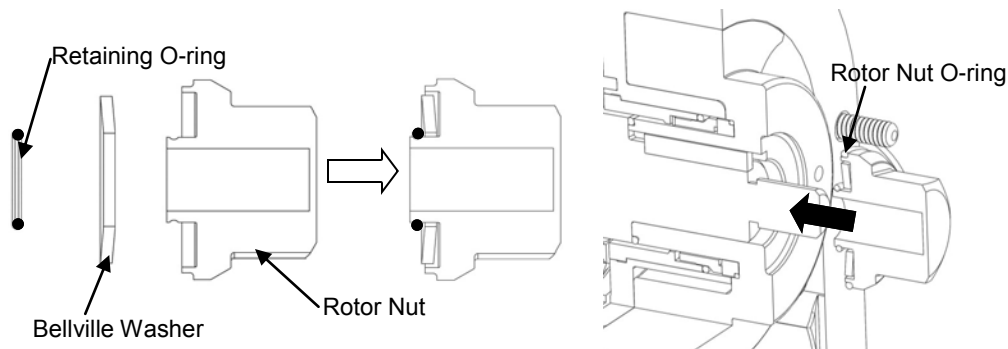

Figure 9: Rotor Nut Assembly

Seal Assembly

7) Thread the nut onto the shaft and tightening it down using the appropriate wrench and a non-metallic wedge to hold the rotor in place (Figure 10). Torque the rotor nuts down using 163 N-m (ZP3 30, See ZP2 manual for correct values) of force. Orientate the rotors as seen in Figure 10 and **Always** tighten the first rotor positioned under the overlap of the opposing rotor. Repeat with the second rotor in the same orientation.

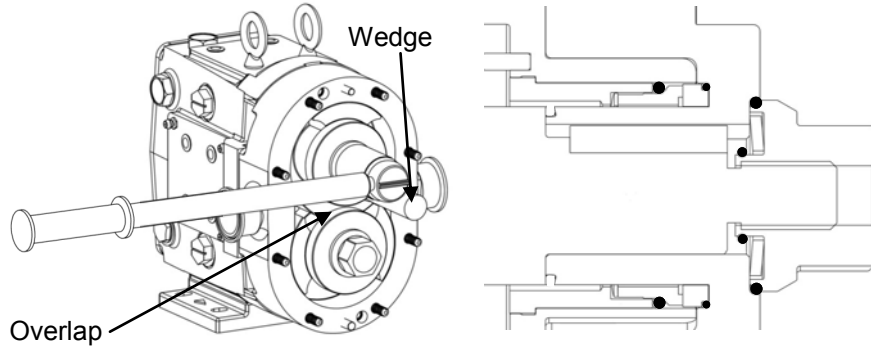

Figure 10: Rotor Assembly

8) Install a new cover o-ring and slide the cover over the studs making sure that the dowels in the body are aligned with the correct dowel holes in the cover (Figure 11). Visually inspect to ensure that the cover o-ring remained in place. Turn the cover nuts (clockwise) by hand and fully tighten them using the appropriate wrench. Tighten the rotor nuts in an opposing manner, as seen on Figure 11, so that the cover is evenly tightened to the body.

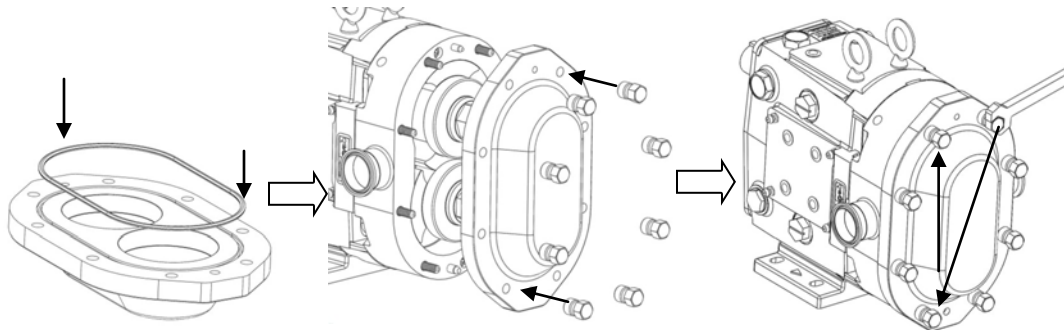

Figure 11: Cover Assembly

Pump Clearances

The performance of a ZP3 is based on the tight clearances between the pump body and the rotors. These clearances are critical to ensure the pump performs up to the system requirements. The clearance between the rotor and the back face of the body is referred to as the backface clearance. Other clearances are shown in Figure 12 and should be in accordance to Table 1. Use shims and a depth micrometer to measure the clearances.

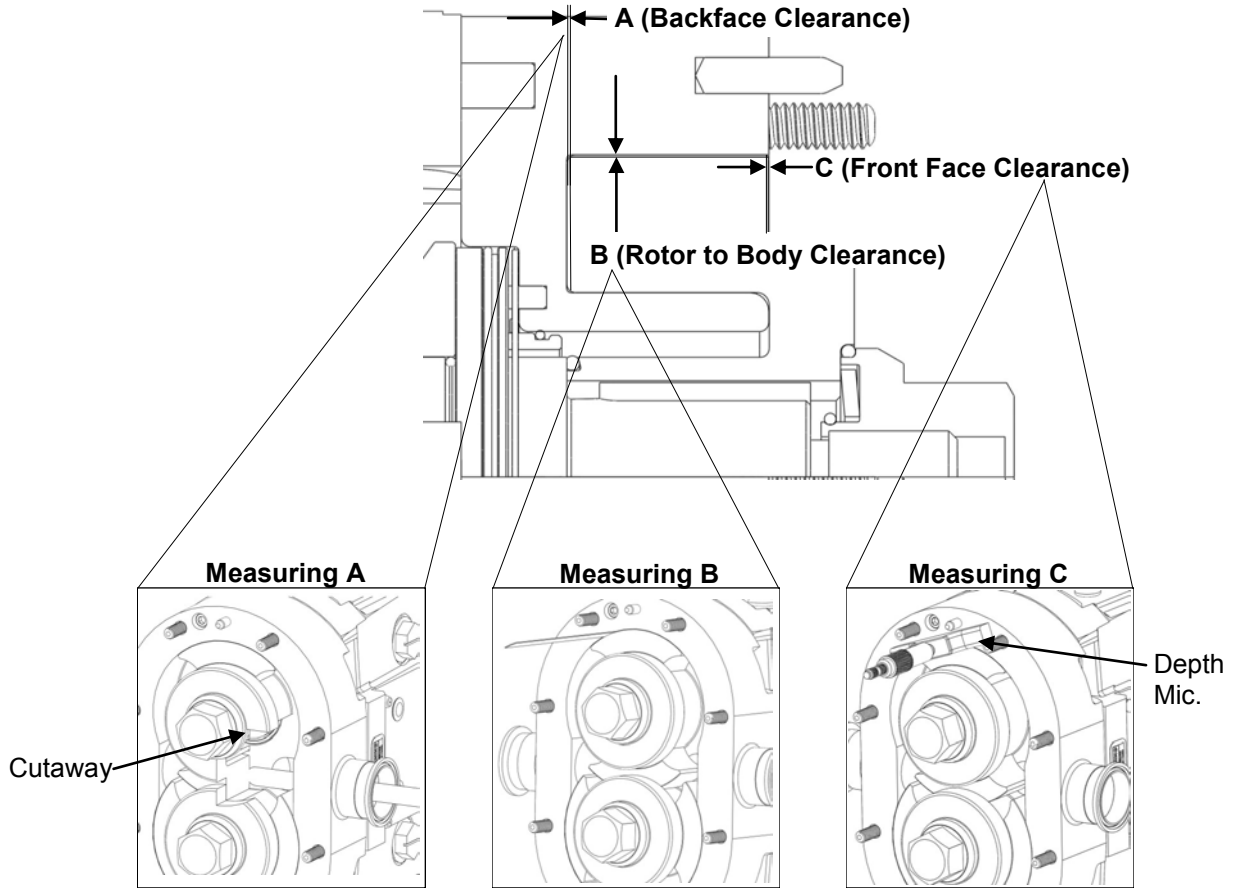

Figure 12: Critical Pump Clearances

Table 1: Critical Pump Clearance Dimensions (Standard Rotors)

ZP3 Model	A (Backface Clearance)		B (Rotor to Body Clearance)		C (Front Face Clearance)	
	Inch	mm	Inch	mm	Inch	mm
6, 15, 18	.002	.05	.002	.05	.005	.13
30, 34	.002	.05	.002	.05	.005	.13
45, 60, 64,	.004	.10	.005	.13	.008	.20
130, 134	.004	.10	.005	.13	.008	.20
180, 220, 224	.005	.13	.006	.15	.008	.20
210, 320	.005	.13	.010	.25	.011	.28

Annual Maintenance

It is important to perform an annual maintenance check of the pump in addition to the preventative maintenance procedures listed on pages 13 and 14. Annual maintenance practices are as follows:

- Check the gear case bearings by measuring the shaft's radial movement with a dial indicator (Figure 22, A). If the movement is greater than or equal to the rotor-to-body clearance found on page 28 (Table 8) the bearings should be replaced.
- Remove the gear casing cover (See page 21 for disassembly information) and inspect the gears for wear and damage (Figure 22, B). Also check for backlash and looseness.
- Inspect the rotors for signs of wear and stress cracks around the areas defined in Figure 22, C. Replace, if necessary.
- Check the pump clearances detailed on page 28 to determine pump wear. Pump wear can be compensated by increasing pump speed.

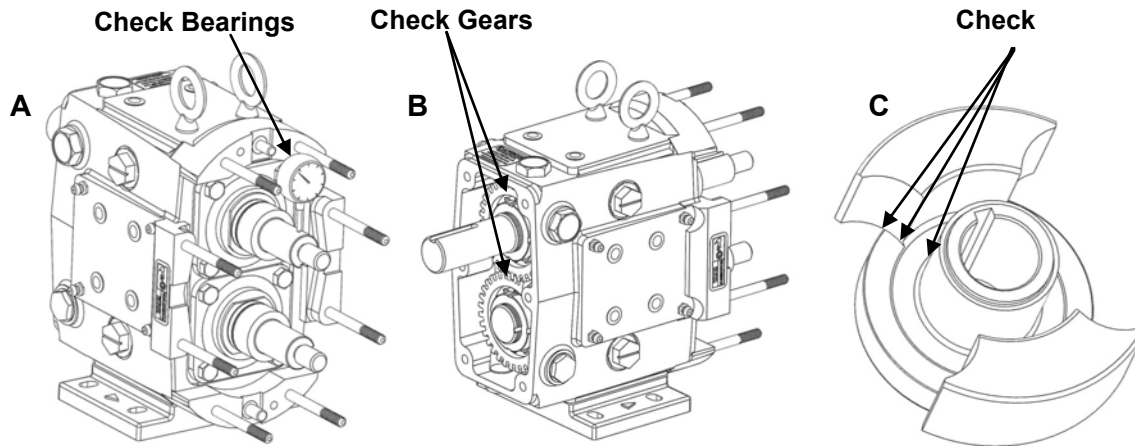

Figure 22: Annual Maintenance Checks

Cleaning

All wetted parts are designed and manufactured to be acceptable by 3A Sanitary Standards. The body, rotors, and seals can be easily disassembled and cleaned simply by removing the cover and rotor nuts. Pump disassembly information begins on page (ZP2 Manual page16).

The ZP3 pumps is clean-in-place (CIP) capable allowing CIP solution to reach all surfaces inside the pump. The fluid velocity (typically 5 ft/sec) and differential pressure (30 psi recommended) are critical components of a correct CIP setup. For additional support, please contact the Engineering Department at Ampco Pumps Company (414-643-1852).



Ampco Pumps Company
2045 W. Mill Road
Glendale, WI 53209
Phone: (800) 737-8671 or (414) 643-1852
Fax: (414) 643-4452
Email: ampcocs@ampcopumps.com

For additional information on the ZP3 series and other Ampco Pumps products, please visit our website: www.ampcopumps.com

Revision Date: November 2011
